

# GT-541

パーツブック  
PARTS BOOK

---

ガーメントプリンタ  
GARMENT PRINTER

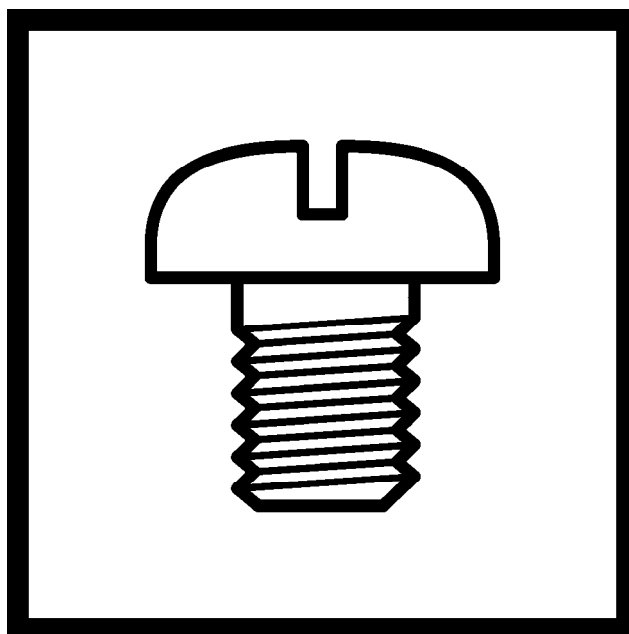

---

**brother**<sup>®</sup>

最新の部品情報は Parts Navigation でご覧いただけます。  
The latest parts information, refer to the Parts Navigation.

<http://partsbook.brother.co.jp/partsnavi/jpn/>  
<http://partsbook.brother.co.jp/partsnavi/eng/>

# パーツブックご利用に際して

1. この本は、2009年6月のデータに基づいて作成されたものです。
2. 部品は予告なしに設計変更される場合があります。
3. 組単位で補給する部品は、破線で示してあります。

## 目 次

A. フレーム関係 .....	1
B1. カバー関係 .....	3
B2. カバー関係 .....	5
C1. プラテン関係 .....	7
C2. プラテン関係 .....	9
D. キャリッジ関係 .....	11
E1. メンテナンス関係 .....	15
E2. メンテナンス関係 .....	19
F. インク供給 .....	21
H. 廃液関係 .....	23
J1. コントロールボックス関係 .....	25
J2. コントロールボックス関係(欧州向) .....	27
K. 電装品関係 .....	29
L. 操作パネル関係 .....	31
Z. 付属品関係 .....	33
Wa1. 警告ラベル .....	35
Wa2. 警告ラベル .....	36
Co. 消耗品 .....	37
Sp. 特別注文部品 .....	39
索引 .....	41

# Notes for using this parts book

1. This book was prepared based on information available in June 2009.
2. Parts are subject to changes in design without prior notice.
3. Parts supplied as complete assemblies are circled by a dotted line.

## CONTENTS

A. Frame mechanism .....	1
B1. Cover mechanism .....	3
B2. Cover mechanism .....	5
C1. Platen mechanism .....	7
C2. Platen mechanism .....	9
D. Carriage mechanism .....	11
E1. Maintenance mechanism .....	15
E2. Maintenance mechanism .....	19
F. Ink supply mechanism .....	21
H. Waste ink mechanism .....	23
J1. Control box mechanism .....	25
J2. Control box mechanism (For Europe only) .....	27
K. Power supply equipment mechanism .....	29
L. Operation panel mechanism .....	31
Z. Accessories .....	33
Wa1. Warning labels .....	35
Wa2. Warning labels .....	36
Co. Consumables .....	37
Sp. Option parts .....	39
Index .....	41

A. フレーム関係 / Frame mechanism

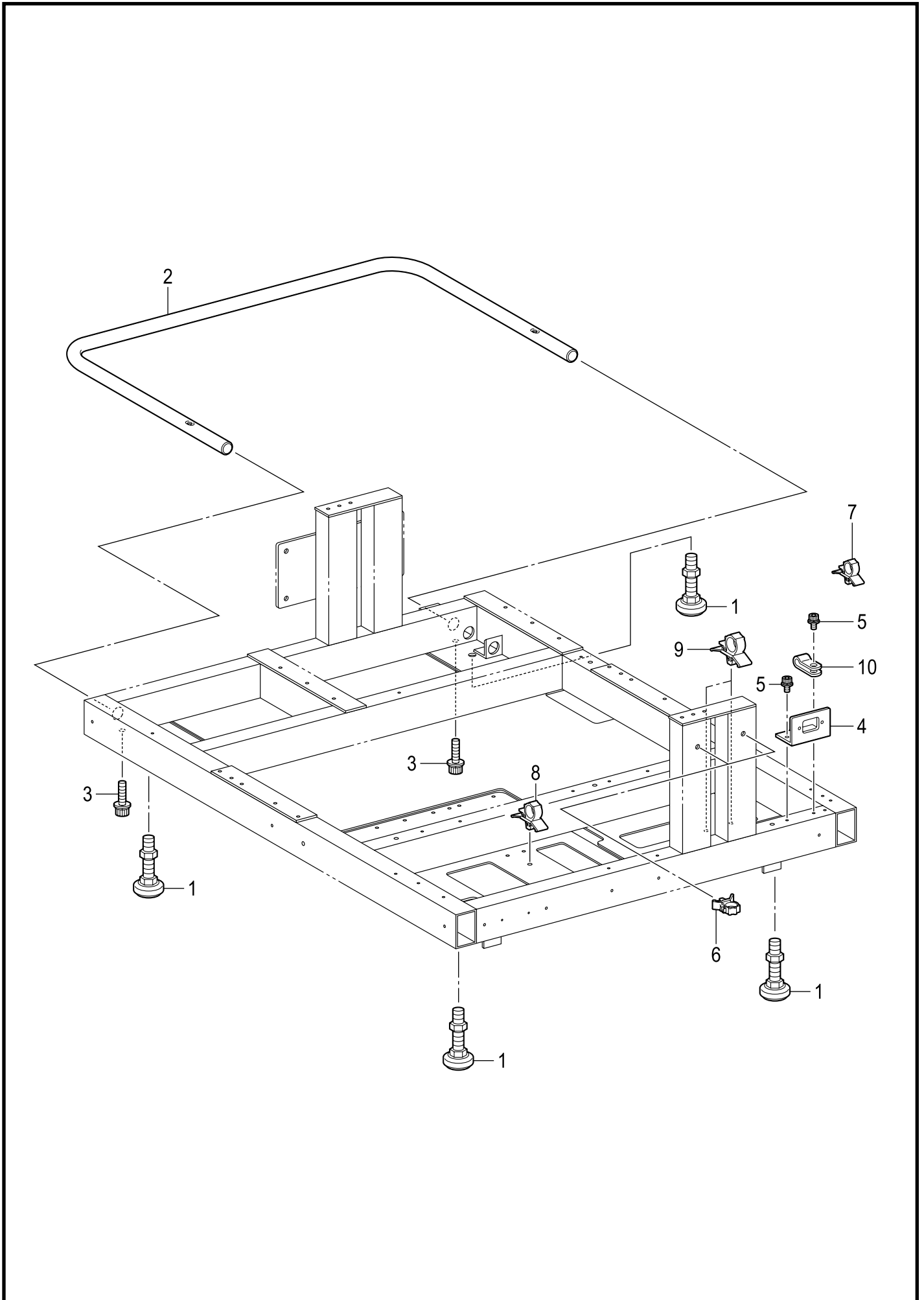

## A. フレーム関係 / Frame mechanism

REF.NO	CODE	Q'TY	品名	NAME OF PARTS	RM
1	SA6007001	4	アジャスタパッド	ADJUSTER PADS	
2	SA6009001	1	キャリバー	CARRY BAR	
3	S47270001	2	アナボルトザクミ6X30	BOLT SOCKET (S/P WASHER)M6X30	
4	SA5515001	1	インレットトリツケイタ	INLET ATTACHMENT PLATE	
5	S55479001	2	アナボルトザクミ4X8	BOLT SOCKET (S/P WASHER) M4X8	
6	S17021000	2	CKSクランプ07-H	CORD CLAMP, 07-H	
7	S17022000	9	CKSクランプ10-H	CORD CLAMP, 10-H	
8	S04505000	1	CKSクランプ13-H	CORD CLAMP, 13-H	
9	S09141000	2	コードクランプ16L	CORD CLAMP, 16-L	
10	149547000	1	コードオサエ	CORD HOLDER 4N	

B1 . カバー関係 / Cover mechanism

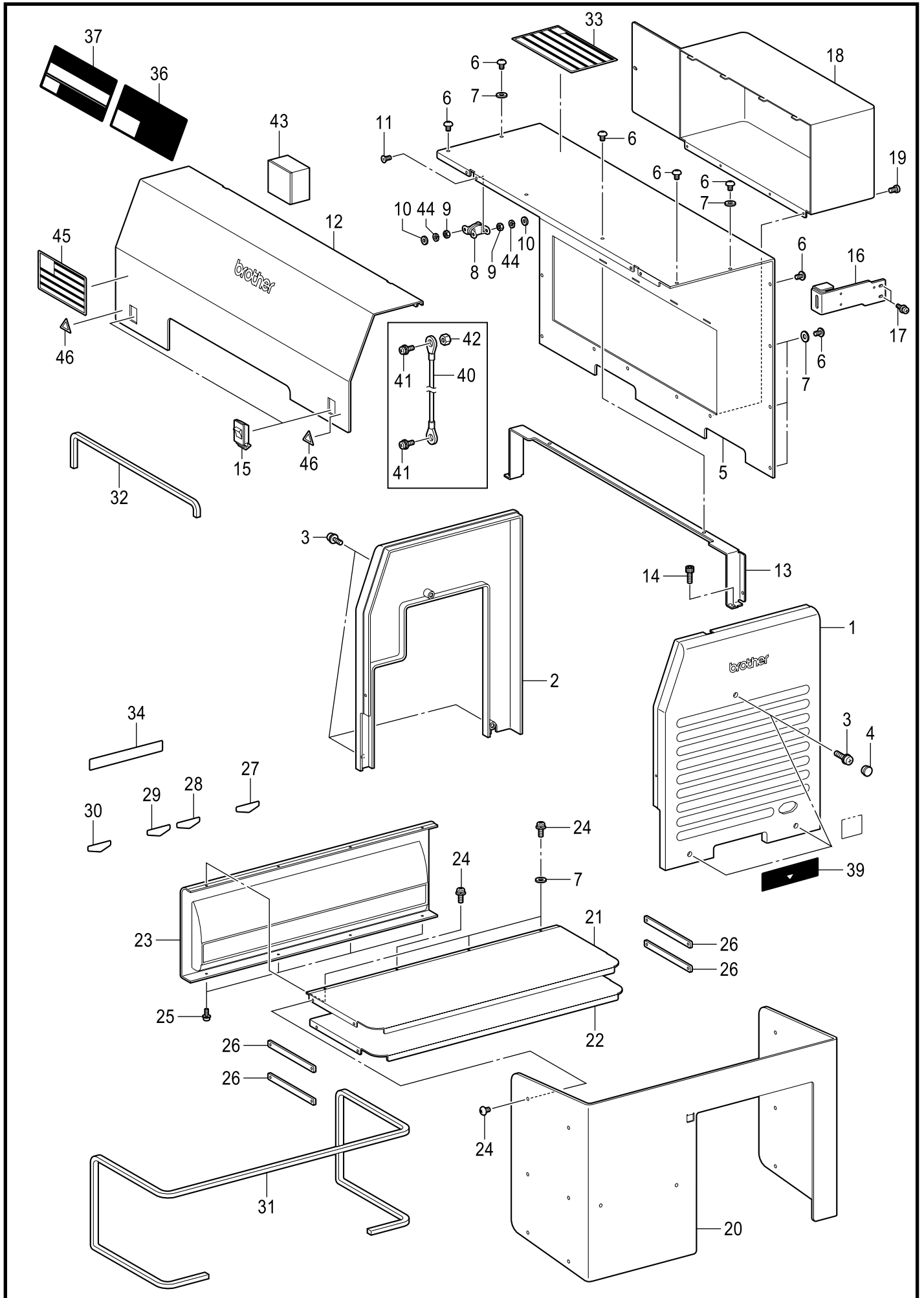

B1. カバー関係 / Cover mechanism

REF.NO	CODE	Q'TY	品名	NAME OF PARTS	RM
1	SA9002001	1	サイドカバー-R	SIDE COVER R	
2	SA9149001	1	サイドカバー-L	SIDE COVER L	
3	0A5401406	6	+ナベザクミ4X14DB	SCREW PAN (S/P WASHER) M4X14	
4	104821001	3	ゴムセン10.5	RUBBER CAP, 10.5	
5	SA6068101	1	ハイメンカバー	BACK COVER	
6	008400604	15	+トラスコ4X6	SCREW TRUSS M4X6	
7	SA6372001	12	ザガネ	WASHER	
8	SA6070001	2	チヨウツガイ	HINGE	
9	021300206	8	2シュナット3	NUT 2 M3	
10	025030236	8	ヒラザガネチュウ3	WASHER PLAIN M 3	
11	004300806	8	+サラコ3X8	SCREW FLAT M3X8	
12	SA6071001	1	ゼンメンカバー	FRONT COVER	
13	SA6072001	1	ゼンメンカバートリツケイタ	FRONT COVER SUPPORT	
14	018061036	2	アナボルト6X10	BOLT SOCKET M6X10	
15	SA6074001	2	スナツプロツク	ROCK LEVER	
16	SA6075001	1	アンゼンSWトリツケイタ	SAFETY SW HOLDER	
17	0A5401006	2	+ナベザクミ4X10DB	SCREW PAN (S/P WASHER) M4X10	
18	SA6076001	1	ウシロカバー	REAR COVER	
19	060400616	5	バインド4X6	SCREW BIND M4X6	
20	SA6079001	1	インクカートリッジカバー-R	INK CARTRIDGE COVER R	
21	SA6080001	1	インクカートリッジカバー-U	INK CARTRIDGE COVER U	
22	SA6081001	1	インクカートリッジタナイタ	INK CARTRIDGE SHELF PLATE	
23	SA9151001	1	インクカートリッジカバー-F	INK CARTRIDGE COVER F	
24	008400604	18	+トラスコ4X6	SCREW TRUSS M4X6	
25	0A5401406	4	+ナベザクミ4X14DB	SCREW PAN (S/P WASHER) M4X14	
26	SA6069001	4	カバートリツケイタ	COVER SUPPORT	
27	SA5619101	1	カートリッジカラーラベルK	CARTRIDGE COLOR LABEL K	
28	SA6380101	1	カートリッジカラーラベルM	CARTRIDGE COLOR LABEL M	
29	SA5659101	1	カートリッジカラーラベルC	CARTRIDGE COLOR LABEL C	
30	SA6381101	1	カートリッジカラーラベルY	CARTRIDGE COLOR LABEL Y	
31	SA5814001	1	トリムL2750	TRIMS L2750	
32	SA5815001	1	トリムL545	TRIMS L545	
33	SA8892101	1	テンバンジュウリョウウシジラベル	TOP COVER CAUTION LABEL	
34	SA6316301	1	ハリチュウイラベル	NEEDLE CAUTION LABEL	
36	SA6315201	1	ヘッドトリセツラベル	HEAD INSTRUCTION LABEL	
37	SA6379201	1	ワイパークリーナーラベル	W-CLEANER INSTRUCTION LABEL	
39	SA6321001	4	トツテラベル	HANDLE LABEL	
43	SA6089001	1	カセットオサエフォーム	BACK UP FORM	
44	028030246	8	バネザガネ2-3	WASHER SPRING 2-3	
45	SA8891101	1	マエカバーシジラベル	FRONT COVER OPERATION LABEL	
46	SA9957002	2	ワ-ニングマーク	INJURY MARK	
			<北米向>	<For USA and Canada >	
40	SA5348001	1	ア-スセン220	GROUND WIRE:220	
41	0A5401006	2	+ナベザクミ4X10DB	SCREW PAN (S/P WASHER) M4X10	
42	021400206	1	2シュナット4	NUT 2 M4	

B2 . カバー関係 / Cover mechanism

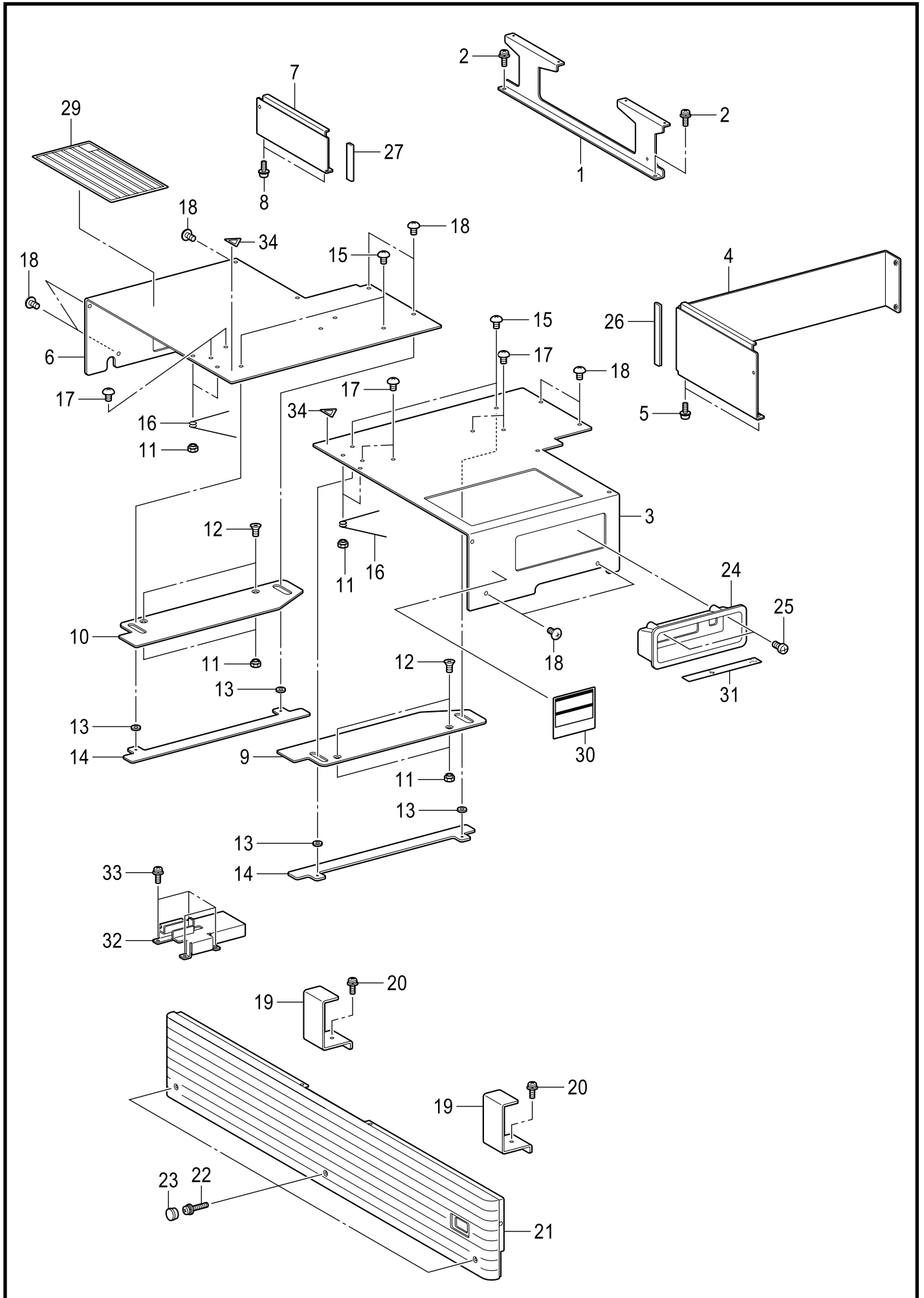



B2. カバー関係 / Cover mechanism

REF.NO	CODE	Q'TY	品名	NAME OF PARTS	RM
1	SA6055001	1	フレームカバー-ササエ	COVER SUPPORT PLATE	
2	0A5401006	2	+ナベザクミ4X10DB	SCREW PAN (S/P WASHER) M4X10	
3	SA6056001	1	フレームカバー-R	FRAME COVER R	
4	SA7947001	1	ゼンメンシタカバー-R	FRONT UNDER COVER R	
5	0A5401006	2	+ナベザクミ4X10DB	SCREW PAN (S/P WASHER) M4X10	
6	SA6058001	1	フレームカバー-L	FRAME COVER L	
7	SA6059001	1	ゼンメンシタカバー-L	FRONT UNDER COVER L	
8	0A5401006	2	+ナベザクミ4X10DB	SCREW PAN (S/P WASHER) M4X10	
9	SA6060001	1	フレームミゾカバー-R	COVER PLATE R	
10	SA6061001	1	フレームミゾカバー-L	COVER PLATE L	
11	SA6062001	12	ダンナツトM4	SHOULDER NUT M4	
12	004400803	4	+サラコ4X8	SCREW, FLAT M4X8	
13	SA6063001	4	スペーサ	SPACER	
14	SA6064001	2	フレームミゾカバー-ササエ	COVER PLATE HOLDER	
15	008400604	4	+トラスコ4X6	SCREW TRUSS M4X6	
16	SA6065001	4	トーションバネ	SPRING	
17	008400604	8	+トラスコ4X6	SCREW TRUSS M4X6	
18	008400604	16	+トラスコ4X6	SCREW TRUSS M4X6	
19	SA5587001	2	フレームマエカバー-ササエ	FRAME FRONT COVER SUPPORT	
20	0A5401006	2	+ナベザクミ4X10DB	SCREW PAN (S/P WASHER) M4X10	
21	SA9150001	1	フレームマエカバー	FRAME FRONT COVER	
22	0A4403006	3	+ナベザクミ4X30DA	SCREW PAN (S/P WASHER) M4X30	
23	104821001	3	ゴムセン10.5	RUBBER CAP, 10.5	
24	SA6078001	1	コネクタカバー	CONNECTOR COVER	
25	062301016	2	ナベコ3X10	SCREW PAN M3X10	
26	SA5816001	1	トリムL115	TRIMS L115	
27	SA5817001	1	トリムL60	TRIMS L60	
29	SA6317201	1	プラテンチュウウイラベル	PLATEN CAUTION LABEL	
30	SA6323201	1	CFカードチュウウイラベル	CF CARD INSTRUCTION LABEL	
31	SA5498001	1	コネクタラベル	CONNECTOR LABEL	
32	SA7922001	1	プーリカバー	PULLEY COVER	
33	S55479001	4	アナボルトザクミ4X8	BOLT SOCKET (S/P WASHER) M4X8	
34	SA9957002	2	ワーニングマーク	INJURY MARK	

C1. プラテン関係 / Platen mechanism

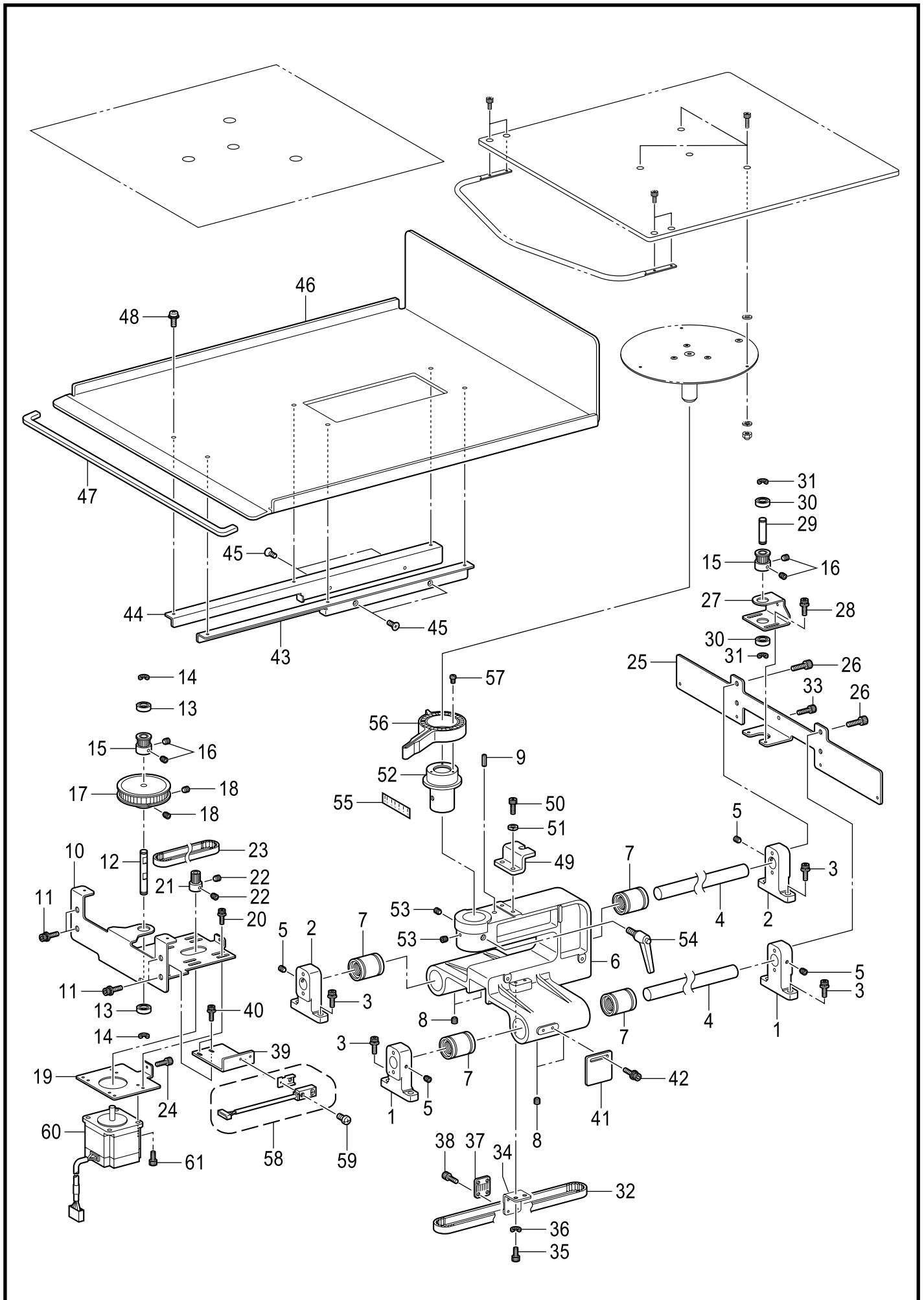

## C1. プラテン関係 / Platen mechanism

REF.NO	CODE	Q'TY	品名	NAME OF PARTS	RM
1	SA5589001	2	ガイドシャフトササエR	GUIDE SHAFT HOLDER R	
2	SA5762001	2	ガイドシャフトササエL	GUIDE SHAFT HOLDER L	
3	S47269001	8	アナボルトザクミ6X20	BOLT, SOCKET (S/P WASHER)M6X20	
4	SA5591001	2	プラテンガイドシャフト	PLATEN GUIDE SHAFT	
5	012060636	4	アナヒラ6X6	SET SCREW SOCKET (FT) M6X6	
6	SA5592001	1	プラテンアーム	PLATEN ARM	
7	SA5593001	4	ボールブツシュ	LINEAR BUSH 16	
8	012500536	4	アナヒラ5X5	SET SCREW SOCKET (FT) M5X5	
9	047603642	1	スプリングピンAW6	PIN SPRING ROLL AW6	
10	SA5594001	1	プーリササエイタF	PULLEY SUPPORT PLATE F	
11	S47269001	4	アナボルトザクミ6X20	BOLT, SOCKET (S/P WASHER)M6X20	
12	SA5595001	1	プーリジクF	PULLEY SHAFT F	
13	070688850	2	Rタマジクウケ688ZZ	BALL BEARING RADIAL 688ZZ	
14	048060342	2	トメワE6	RETAINING RING E6	
15	SA5596001	2	プラテンプーリ	PLATEN PULLEY	
16	012500536	4	アナヒラ5X5	SET SCREW SOCKET (FT) M5X5	
17	SA5597001	1	ゲンソクプーリ	REDUCTION PULLEY	
18	012500536	2	アナヒラ5X5	SET SCREW SOCKET (FT) M5X5	
19	SA5598001	1	モータリツケイタ	MOTOR BRACKET	
20	S55479001	4	アナボルトザクミ4X8	BOLT SOCKET (S/P WASHER) M4X8	
21	SA5599001	1	プラテンモータプーリ	PLATEN MOTOR PULLEY	
22	012400436	2	アナヒラ4X4	SET SCREW SOCKET (FT) M4X4	
23	SA5600001	1	プラテンモータベルト	PLATEN MOTOR BELT	
24	018402036	1	アナボルト4X20	BOLT SOCKET M4X20	
25	SA5601001	1	プーリササエイタR	PULLEY SUPPORT PLATE R	
26	S47269001	4	アナボルトザクミ6X20	BOLT, SOCKET (S/P WASHER)M6X20	
27	SA5602001	1	プーリダイ	PULLEY BASE PLATE	
28	S55479001	2	アナボルトザクミ4X8	BOLT SOCKET (S/P WASHER) M4X8	
29	SA5603001	1	プーリジクR	PULLEY SHAFT R	
30	070688850	2	Rタマジクウケ688ZZ	BALL BEARING RADIAL 688ZZ	
31	048060342	2	トメワE6	RETAINING RING E6	
32	SA5604001	1	プラテンベルト	PLATEN BELT	
33	018402036	1	アナボルト4X20	BOLT SOCKET M4X20	
34	SA7979001	1	ベルトリツケイタ	BELT SETTING PLATE	
35	018501036	2	アナボルト5X10	BOLT SOCKET M5X10	
36	028050246	2	バネザガネ2-5	WASHER SPRING 2-5	
37	SA7980001	1	ベルトホルダー	BELT HOLDER	
38	018400836	4	アナボルト4X8	BOLT SOCKET M4X8	
39	SA5607001	1	センサーリツケイタ	SENSOR BRACKET	
40	S55479001	2	アナボルトザクミ4X8	BOLT SOCKET (S/P WASHER) M4X8	
41	SA5608001	1	プラテンセンサードグ	PLATEN SENSOR DOG	
42	S55479001	2	アナボルトザクミ4X8	BOLT SOCKET (S/P WASHER) M4X8	
43	SA5609001	1	トレイササエイタR	TRAY SUPPORT PLATE R	
44	SA6073001	1	トレイササエイタL	TRAY SUPPORT PLATE L	
45	004401003	4	+サラコ4X10	SCREW, FLAT M4X10	
46	SA5610001	1	Tシャツトレイ	T-SHIRT TRAY	
47	SA5818101	1	トリムL490	TRIMS L490	
48	0A5401006	6	+ナベザクミ4X10DB	SCREW PAN (S/P WASHER) M4X10	
49	SA5611001	1	プラテンイチギメイタ	PLATEN POSITIONING PLATE	
50	018501036	2	アナボルト5X10	BOLT SOCKET M5X10	
51	028050246	2	バネザガネ2-5	WASHER SPRING 2-5	
52	SA5612001	1	プラテンジクウケ	BUSH PLATEN SHAFT	
53	012060636	2	アナヒラ6X6	SET SCREW SOCKET (FT) M6X6	
54	SA5443001	1	クランプレバーM6	CLAMP LEVER M6	
55	SA5446001	1	タカサメモリシール	HEIGHT SCALE LABEL	
56	SA5613001	1	タカサチヨウセツレバー	HEIGHT ADJUST LEVER	
57	060400616	3	バインド4X6	SCREW BIND M4X6	
58	SA5379001	1	プラテンゲンテンセンサクミ	PLATEN ORG SENSOR ASSY	
59	062300816	1	ナベコ3X8	SCREW PAN M3X8	
60	SA5399001	1	プラテンモータクミ	PLATEN MOTOR ASSY	
61	018400836	4	アナボルト4X8	BOLT SOCKET M4X8	

C2 . プラテン関係 / Platen mechanism

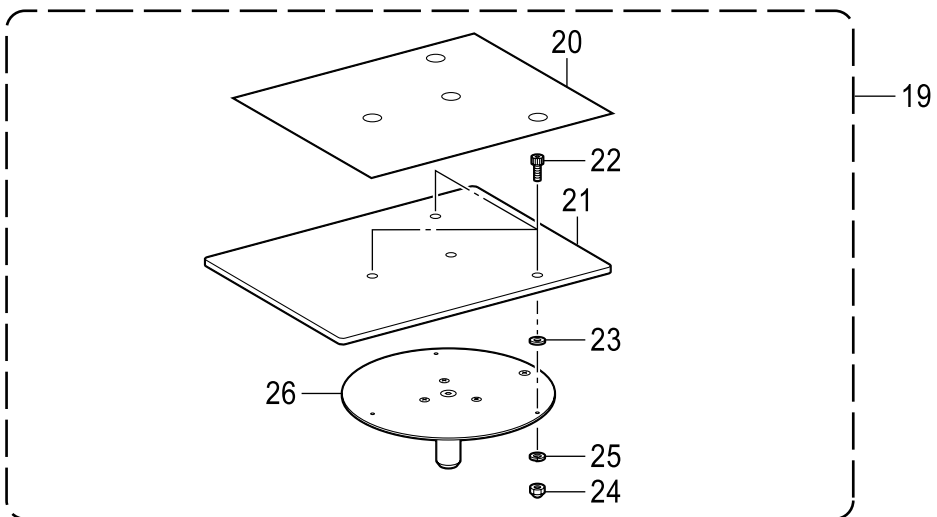
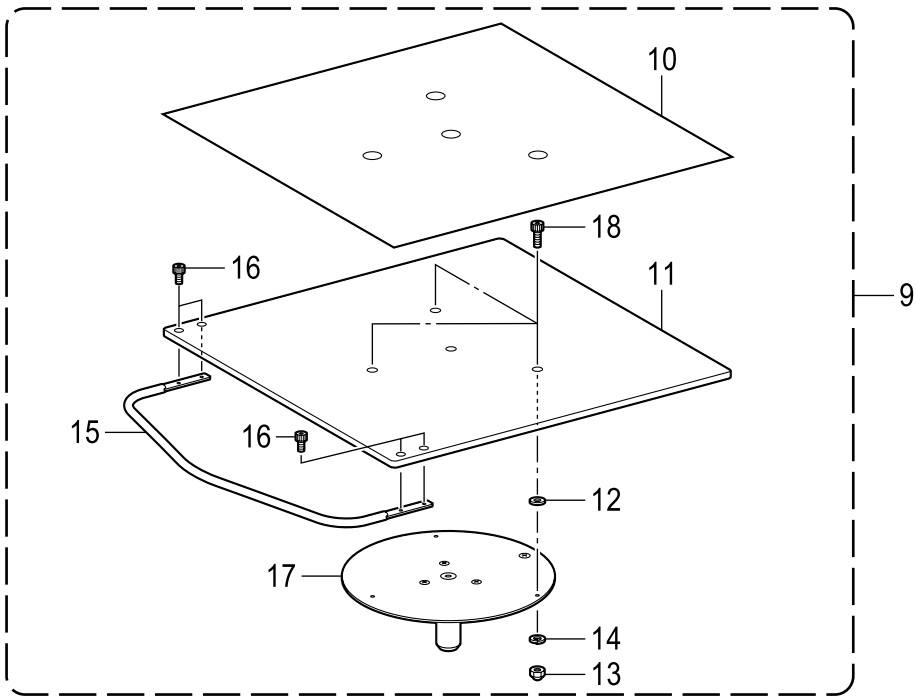
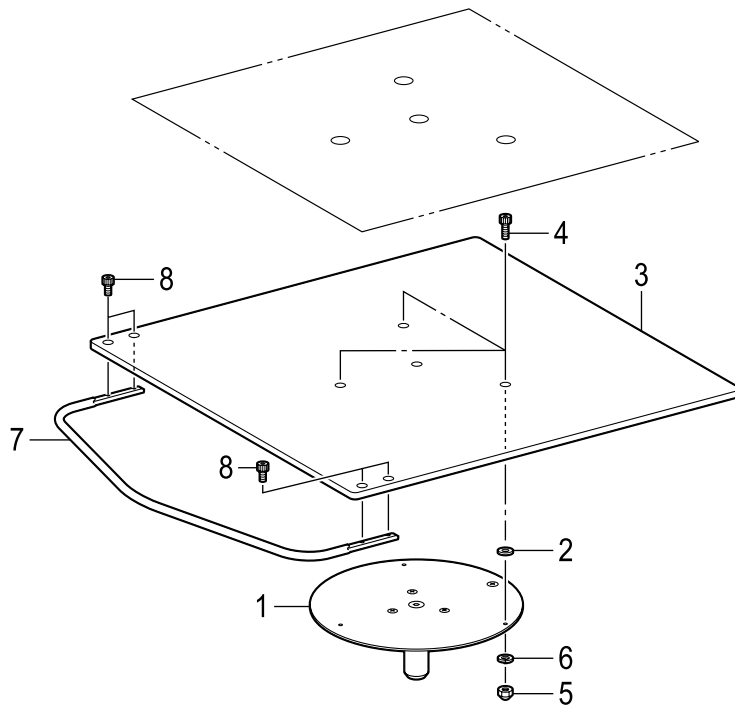

C2. プラテン関係 / Platen mechanism

REF.NO	CODE	Q'TY	品名	NAME OF PARTS	RM
1	SA5614001	1	プラテンササエクミ	PLATEN SUPPORT ASSY	
2	154599000	3	ソレノイドクツシヨン	SOLENOID CUSHION	
3	SA5621101	1	プラテンテンイタ14X16	PLATEN TOP PLATE 14X16	
4	018401236	3	アナボルト4X12	BOLT SOCKET M4X12	
5	S00505001	3	ロツカクフクロナツトM4	NUT, CAP M4	
6	028040246	3	バネザガネ2-4	WASHER SPRING 2-4	
7	SA5622001	1	シヨルダ-バー	SHOULDER BAR	
8	018400636	4	アナボルト4X6	BOLT SOCKET M4X6	
			<特別注文部品>	<Option parts>	
9	SA6399301	1	ユ-スプラテン	YOUTH PLATEN	
10	SA6401201	1	プラテンシートS	PLATEN SHEET S	
11	SA6402101	1	プラテンテンイタ10X12	PLATEN TOP PLATE 10X12	
12	154599000	3	ソレノイドクツシヨン	SOLENOID CUSHION	
13	S00505001	3	ロツカクフクロナツトM4	NUT, CAP M4	
14	028040246	3	バネザガネ2-4	WASHER SPRING 2-4	
15	SA6403001	1	シヨルダ-バーS	SHOULDER BAR S	
16	018400636	4	アナボルト4X6	BOLT SOCKET M4X6	
17	SA5614001	1	プラテンササエクミ	PLATEN SUPPORT ASSY	
18	018401236	3	アナボルト4X12	BOLT SOCKET M4X12	
19	SA8213301	1	ベビ-プラテン	BABY PLATEN	
20	SA8211101	1	プラテンシートSS	PLATEN SHEET SS	
21	SA8212101	1	プラテンテンイタ7X8	PLATEN TOP PLATE 7X8	
22	018401236	3	アナボルト4X12	BOLT SOCKET M4X12	
23	154599000	3	ソレノイドクツシヨン	SOLENOID CUSHION	
24	S00505001	3	ロツカクフクロナツトM4	NUT, CAP M4	
25	028040246	3	バネザガネ2-4	WASHER SPRING 2-4	
26	SA5614001	1	プラテンササエクミ	PLATEN SUPPORT ASSY	

D. キャリッジ関係 / Carriage mechanism

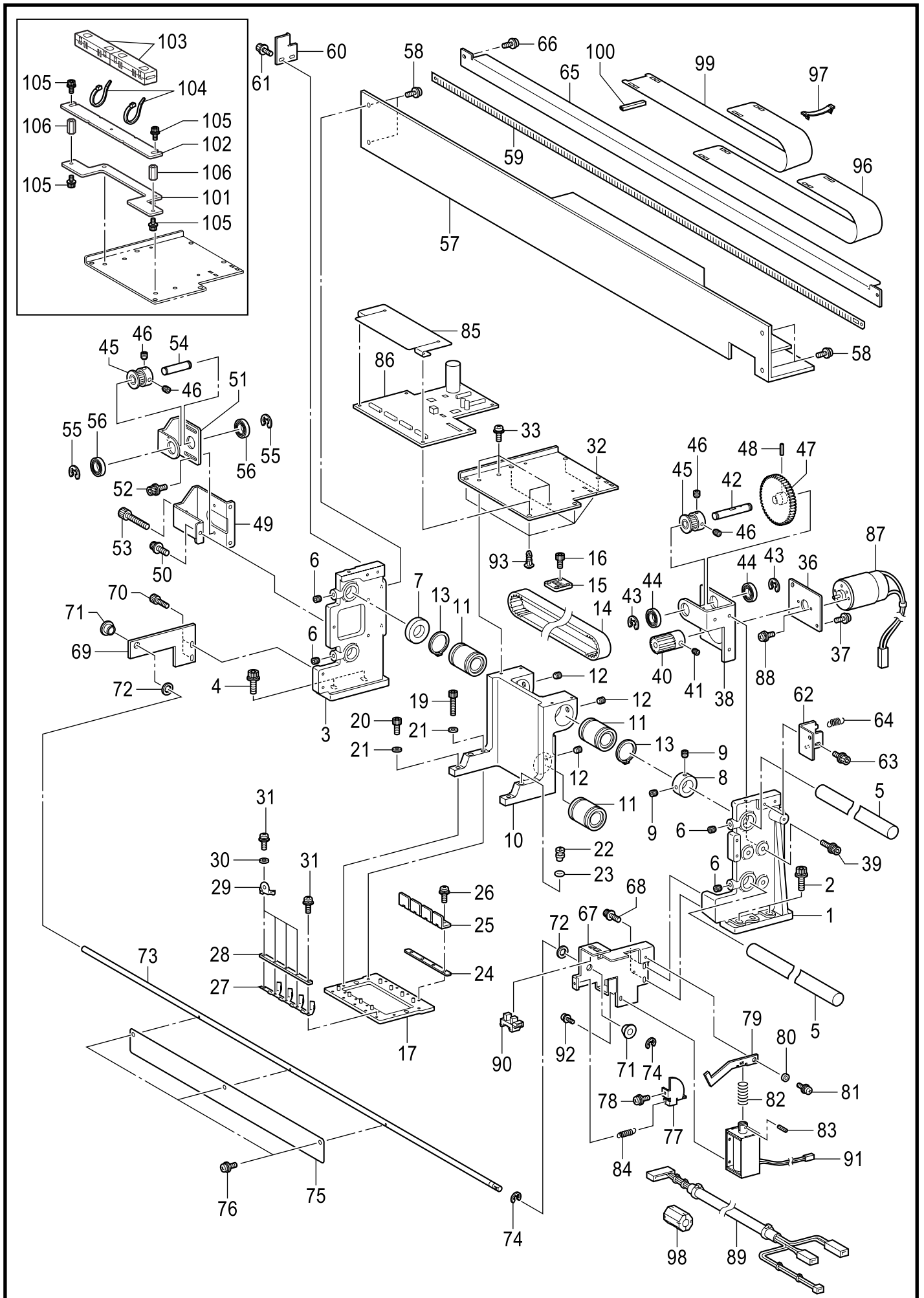

## D. キャリッジ関係 / Carriage mechanism

REF.NO	CODE	Q'TY	品名	NAME OF PARTS	RM
1	SA5438001	1	キャリッジササエR	CARRIAGE SUPPORT R	
2	S47269001	2	アナボルトザクミ6X20	BOLT, SOCKET (S/P WASHER)M6X20	
3	SA5439001	1	キャリッジササエL	CARRIAGE SUPPORT L	
4	S47269001	2	アナボルトザクミ6X20	BOLT, SOCKET (S/P WASHER)M6X20	
5	SA5440001	2	キャリッジガイドシャフト	CARRIAGE GUIDE SHAFT	
6	012060636	4	アナヒラ6X6	SET SCREW SOCKET (FT) M6X6	
7	SA5441001	1	ストッパ	STOPPER	
8	S45316001	1	セットカラ	SET SCREW COLLAR	
9	012060636	2	アナヒラ6X6	SET SCREW SOCKET (FT) M6X6	
10	SA7902001	1	キャリッジクミ	CARRIAGE ASSY	
11	SA5593001	3	ボールブツシュ	LINEAR BUSH 16	
12	012500536	3	アナヒラ5X5	SET SCREW SOCKET (FT) M5X5	
13	048280142	2	トメワジクヨウC28	RETAINING RING EXTERNAL C28	
14	SA5445001	1	キャリッジベルト	CARRIAGE BELT	
15	SA7980001	1	ベルトホルダー	BELT HOLDER	
16	018400836	4	アナボルト4X8	BOLT SOCKET M4X8	
17	SA7695001	1	ヘッドホルダクミ	HEAD HOLDER ASSY	
19	018402536	2	アナボルト4X25	BOLT SOCKET M4X25	
20	018401236	2	アナボルト4X12	BOLT SOCKET M4X12	
21	026040236	4	ヒラザガネミガキ4	WASHER PLAIN M 4	
22	SA5451001	1	ヘンシンピン	ADJUSTING STUD	
23	081001670	1	OリングPW1	O RING PW1	
24	SA5452001	1	ヘッドバネスペーサウシロ	HEAD SPRING SPACER,BACK	
25	SA5453001	1	ヘッドホジバネウシロ	HEAD HOLD SPRING ,BACK	
26	0A5300606	4	+ナベザクミ3X6DB	SCREW PAN (S/P WASHER) M3X6	
27	SA5516001	1	ヘッドオシバネ	SPRING,PLATE	
28	SA5454001	1	ヘッドバネスペーサマエ	HEAD SPRING SPACER,FRONT	
29	SA5455001	4	ヘッドホジバネマエ	HEAD HOLD SPRING FRONT	
30	SA5456001	4	ザガネ	WASHER	
31	0A5300606	5	+ナベザクミ3X6DB	SCREW PAN (S/P WASHER) M3X6	
32	SA8042001	1	ヘッドキバンプレート	HEAD PCB SUPPORT PLATE	
33	0A5401006	4	+ナベザクミ4X10DB	SCREW PAN (S/P WASHER) M4X10	
36	SA5460001	1	モータプレート	MOTOR SETTING PLATE	
37	0A5401006	2	+ナベザクミ4X10DB	SCREW PAN (S/P WASHER) M4X10	
38	SA5461001	1	キャリッジモータホルダ	CARRIAGE MOTOR HOLDER	
39	3A6001003	3	アナツキザクミ5X20DB	BOLT SOCKET (S/P WASHER) M5X20	
40	SA5464001	1	ギアM0.5Z18	GEAR M0.5Z18	
41	012300536	1	アナヒラ3X5	SET SCREW SOCKET (FT) M3X5	
42	SA5465001	1	プーリジク	PULLEY SHAFT	
43	048060342	2	トメワE6	RETAINING RING E6	
44	070688850	2	Rタマジクウケ688ZZ	BALL BEARING RADIAL 688ZZ	
45	SA5466001	2	キャリッジプーリ	CARRIAGE PULLEY	
46	012500536	4	アナヒラ5X5	SET SCREW SOCKET (FT) M5X5	
47	SA5467001	1	ギアM0.5Z120	GEAR M0.5Z120	
48	047201442	1	スプリングピンAW2	PIN SPRING ROLL AW2	
49	SA5468001	1	プーリホルダベース	PULLEY HOLDER BASE	
50	S55481001	3	アナボルトザクミ4X12	BOLT, SOCKET (S/P WASHER)M4X12	
51	SA5602001	1	プーリダイ	PULLEY BASE PLATE	
52	S55481001	2	アナボルトザクミ4X12	BOLT, SOCKET (S/P WASHER)M4X12	
53	018402036	1	アナボルト4X20	BOLT SOCKET M4X20	
54	SA5603001	1	プーリジクR	PULLEY SHAFT R	
55	048060342	2	トメワE6	RETAINING RING E6	
56	070688850	2	Rタマジクウケ688ZZ	BALL BEARING RADIAL 688ZZ	
57	SA5471001	1	キャリッジウシロイタ	CARRIAGE BACK PLATE	
58	0A5401006	4	+ナベザクミ4X10DB	SCREW PAN (S/P WASHER) M4X10	
59	SA5472001	1	エンコーダストリップ	ENCODER STRIP	
60	SA5473001	1	エンコーダササエL	ENCODER STRIP SUPPORT L	
61	S55481001	2	アナボルトザクミ4X12	BOLT, SOCKET (S/P WASHER)M4X12	
62	SA5474001	1	エンコーダササエR	ENCODER STRIP SUPPORT R	

D. キャリッジ関係 / Carriage mechanism

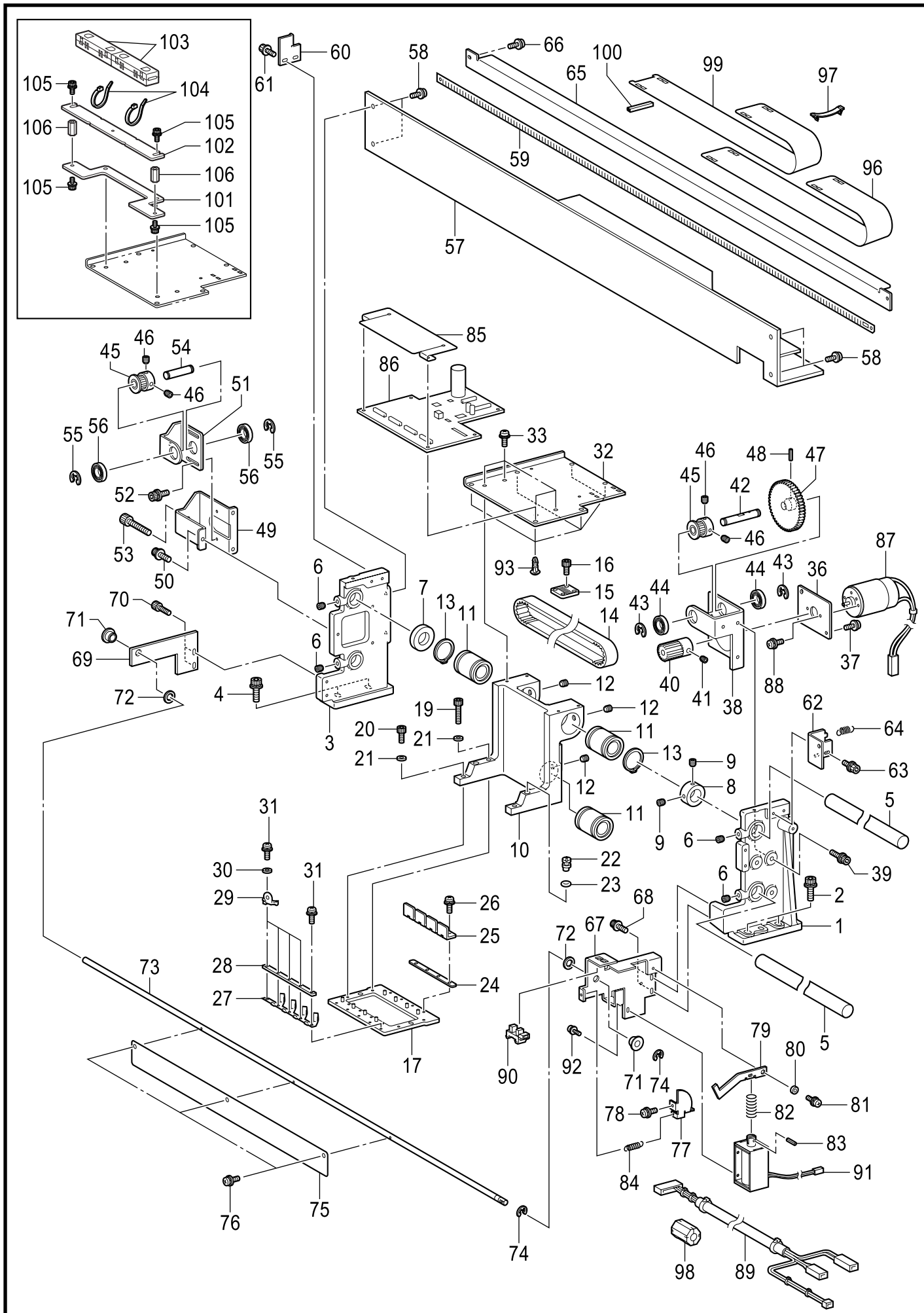



## D. キャリッジ関係 / Carriage mechanism

REF.NO	CODE	Q'TY	品名	NAME OF PARTS	RM
63	S55481001	2	アナボルトザクミ4X12	BOLT SOCKET (S/P WASHER) M4X12	
64	S03607001	1	ボタンヒラキツメバネ	SPRING	
65	SA5475001	1	エンコ-ダカバー	ENCODER STRIP COVER	
66	0A5401006	2	+ナベザクミ4X10DB	SCREW PAN (S/P WASHER) M4X10	
67	SA5476001	1	センサーイタシジタR	SENSORFLAP SUPPORT PLATE R	
68	S55481001	2	アナボルトザクミ4X12	BOLT SOCKET (S/P WASHER) M4X12	
69	SA5477001	1	センサーイタシジタL	SENSORFLAP SUPPORT PLATE L	
70	S55481001	2	アナボルトザクミ4X12	BOLT SOCKET (S/P WASHER) M4X12	
71	SA5933001	2	ムキュウユブツシユ6	OIL FREE BUSHING 6X5	
72	XA0199051	2	CSTメワCSTW-8	RETAINING RING,CS8	
73	SA5519001	1	センサーイタジク	SENSOR FLAP SHAFT	
74	048050342	2	トメワE5	RETAINING RING E5	
75	SA5481001	1	センサーイタ	SENSOR FLAP	
76	0A5300606	3	+ナベザクミ3X6DB	SCREW PAN (S/P WASHER) M3X6	
77	SA5482001	1	センサーイタドグ	SENSOR FLAP DOG	
78	0A5300606	1	+ナベザクミ3X6DB	SCREW PAN (S/P WASHER) M3X6	
79	SA5483001	1	センサーイタタイヒイタ	SENSORFLAP RELEASE PLATE	
80	SA5484001	1	カラ-3	COLLAR ,3	
81	0A5300606	1	+ナベザクミ3X6DB	SCREW PAN (S/P WASHER) M3X6	
82	SA5485001	1	ソレノイドバネ	SPRING	
83	047301042	1	スプリングピンAW3	PIN SPRING ROLL AW3	
84	SA5953001	1	ヒキバネ4.9X20	SPRING EXTENSION 4.9X20	
85	SA8043001	1	キャリッジキバンカバー	CARRIAGE PCB COVER	
86	SA5376101	1	キャリッジキバンクミ	CARRIAGE PCB ASSY	
87	SA5395001	1	キャリッジモータ	CARRIAGE MOTOR	
88	0A5300606	2	+ナベザクミ3X6DB	SCREW PAN (S/P WASHER) M3X6	
89	SA5397101	1	ジャムセンサハーネス	HARNES:JAM SENSOR	
90	LG2239001	1	PHINTSG-2482A	PHOTO INTERRUPTER:SG-2482A	
91	SA5664001	1	ソレノイドMD272-3	SOLENOID:MD-272-3	
92	0A5300606	2	+ナベザクミ3X6DB	SCREW PAN (S/P WASHER) M3X6	
93	S34413000	6	スペーサ-	SPACER	
96	SA5518001	1	ヘッドヨウFFCサポート	FFC SUPPORT,HEAD	
97	SA6053001	6	クランプFCR-30VO	CLAMP:FCR-30VO	
98	S40660000	1	EMIコアTFC16-8-16	EMI CORE, TFC16-8-16	
99	SA5517001	1	ヘッドヨウFFCサポートナカ	FFC SUPPORT INSIDE, HEAD	
100	SA5520001	1	エッジガードCE-012	EDGE GUARD CE-012	
			<日本、欧州向>	<For Japan and Europe>	
101	SA9087001	1	コアササエベース	CORE PLATE BASE	
102	SA9086001	1	コアササエイタ	CORE PLATE	
103	SA8913101	2	フェライトコアZCAT6819	FERRITE CORE: ZCAT6819-5230D	
104	S04159000	2	バンド1M	BAND 1M	
105	S55479001	4	アナボルトザクミ4X8	BOLT SOCKET (S/P WASHER) M4X8	
106	SA9088001	2	スペーサ4SP-15	SAPCER:4SP-15	

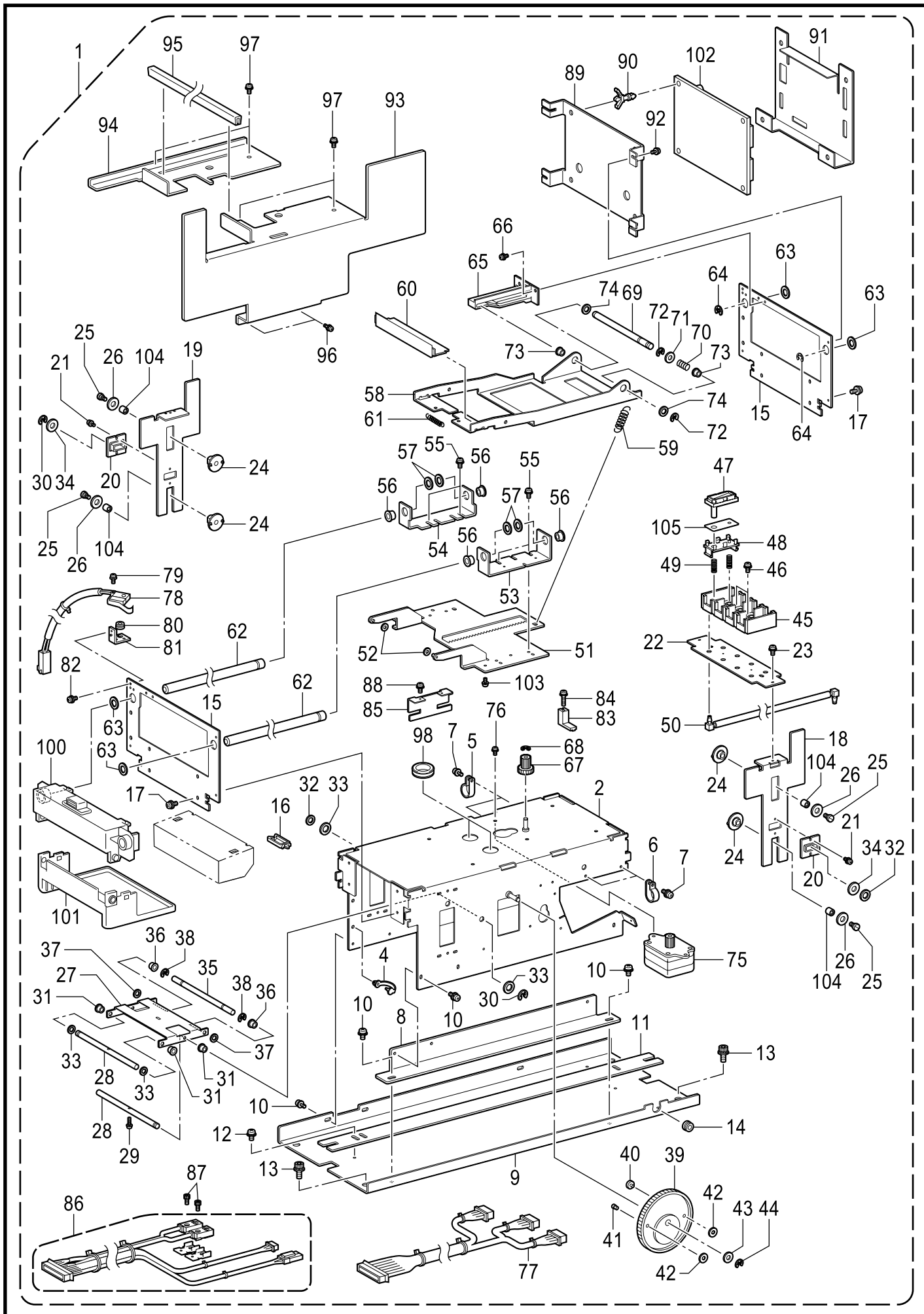

## E1. メンテナンス関係 / Maintenance mechanism

REF.NO	CODE	Q'TY	品名	NAME OF PARTS	RM
1	SA6252001	1	メンテホンタイクミ	MNT MAIN ASSY	
2	SA7694001	1	メンテフレームカシメクミ	MNT FRAME SUB ASSY	
4	SA5916001	4	スピードクランプ	CLAMP	
5	625010000	2	ナイロンクランプNK-2N	NYLON CLAMP NK-2N	
6	624771000	2	ナイロンクランプNK-7N	NYLON CLAMP NK-7N	
7	0A5400806	4	+ナベザクミ4X8DB	SCREW PAN (S/P WASHER) M4X8	
8	SA5917001	1	メンテコティイタ	MNT LOCATING PLATE	
9	SA7946001	1	メンテユニットベース	MNT BASE TORAY	
10	0A5400806	8	+ナベザクミ4X8DB	SCREW PAN (S/P WASHER) M4X8	
11	SA5736101	1	アジャストプレート	ADJUST PLATE	
12	0A5400806	2	+ナベザクミ4X8DB	SCREW PAN (S/P WASHER) M4X8	
13	S42446001	4	アナボルトザクミ6X14	BOLT SOCKET (S/P WASHER)M6X14	
14	SA5921001	1	グロメット	GROMMET	
15	SA5922001	2	フレームFR	FRAME F&R	
16	S43275000	2	コードクランプWS2NS	CORD CLAMP, WS2NS	
17	0A5400806	8	+ナベザクミ4X8DB	SCREW PAN (S/P WASHER) M4X8	
18	SA5925001	1	CLガイドプレートR	CL GUIDE R	
19	SA5926001	1	CLガイドプレートL	CL GUIDE L	
20	SA5927001	2	CLガイドブツシュ	CL GUIDE BUSHING	
21	0A5300806	4	+ナベザクミ3X8DB	SCREW PAN (S/P WASHER) M3X8	
22	SA5928001	1	CLガイドシタ	CL GUIDE LOWER	
23	0A5400806	2	+ナベザクミ4X8DB	SCREW PAN (S/P WASHER) M4X8	
24	SA5929001	4	CLガイドカラ	CL GUIDE COLLAR	
25	0A5401406	4	+ナベザクミ4X14DB	SCREW PAN (S/P WASHER) M4X14	
26	026060250	4	ヒラザガネミガキ6	WASHER PLAIN M 6	
27	SA5931001	1	CLクドウイタ	CL DRIVE PLATE	
28	SA5932001	2	CLクドウシャフト	CL DRIVE SHAFT	
29	0A5301606	1	+ナベザクミ3X16DB	SCREW PAN (S/P WASHER) M3X16	
30	048040346	2	トメワE4	RETAINING RING E4	
31	SA5933001	4	ムキュウユブツシュ6	OIL FREE BUSHING 6X5	
32	SA5934001	2	CSTメワ6	RETAINING RING CSTW-6	
33	XA0199001	4	CSTメワCSTW-8	RETAINING RING,CS8	
34	026060250	2	ヒラザガネミガキ6	WASHER PLAIN M 6	
35	SA5935001	1	CLカムフオロア	CL CAM FOLLOWER	
36	SA5933001	2	ムキュウユブツシュ6	OIL FREE BUSHING 6X5	
37	XA0199001	2	CSTメワCSTW-8	RETAINING RING,CS8	
38	048040346	2	トメワE4	RETAINING RING E4	
39	SA5937001	1	CLカム	CL DRIVE CAM	
40	SA5938001	1	CLカムドグピンL	CL CAM DOG LARGE	
41	SA5939001	1	CLカムドグピンS	CL CAM DOG SMALL	
42	X56655001	2	CSTメワCSTW-3.5	RETAINING RING: CSTW-3.5	
43	026060250	1	ヒラザガネミガキ6	WASHER PLAIN M 6	
44	048040346	1	トメワE4	RETAINING RING E4	
45	SA5940001	1	キャツブリフター	CAP LIFTER FRAME	
46	0A5300806	2	+ナベザクミ3X8DB	SCREW PAN (S/P WASHER) M3X8	
47	SA5941001	4	キャツブゴム	CAP RUBBER	
48	SA7692001	4	キャツブホルダー	CAP RUBBER HOLDER	
49	SA5943001	8	オシバネ8X15	SPRING COMPRESSION 8X15	
50	SA6289101	4	キャップチューブクミ	CAPPING TUBE ASSY	

E1 . メンテナンス関係 / Maintenance mechanism

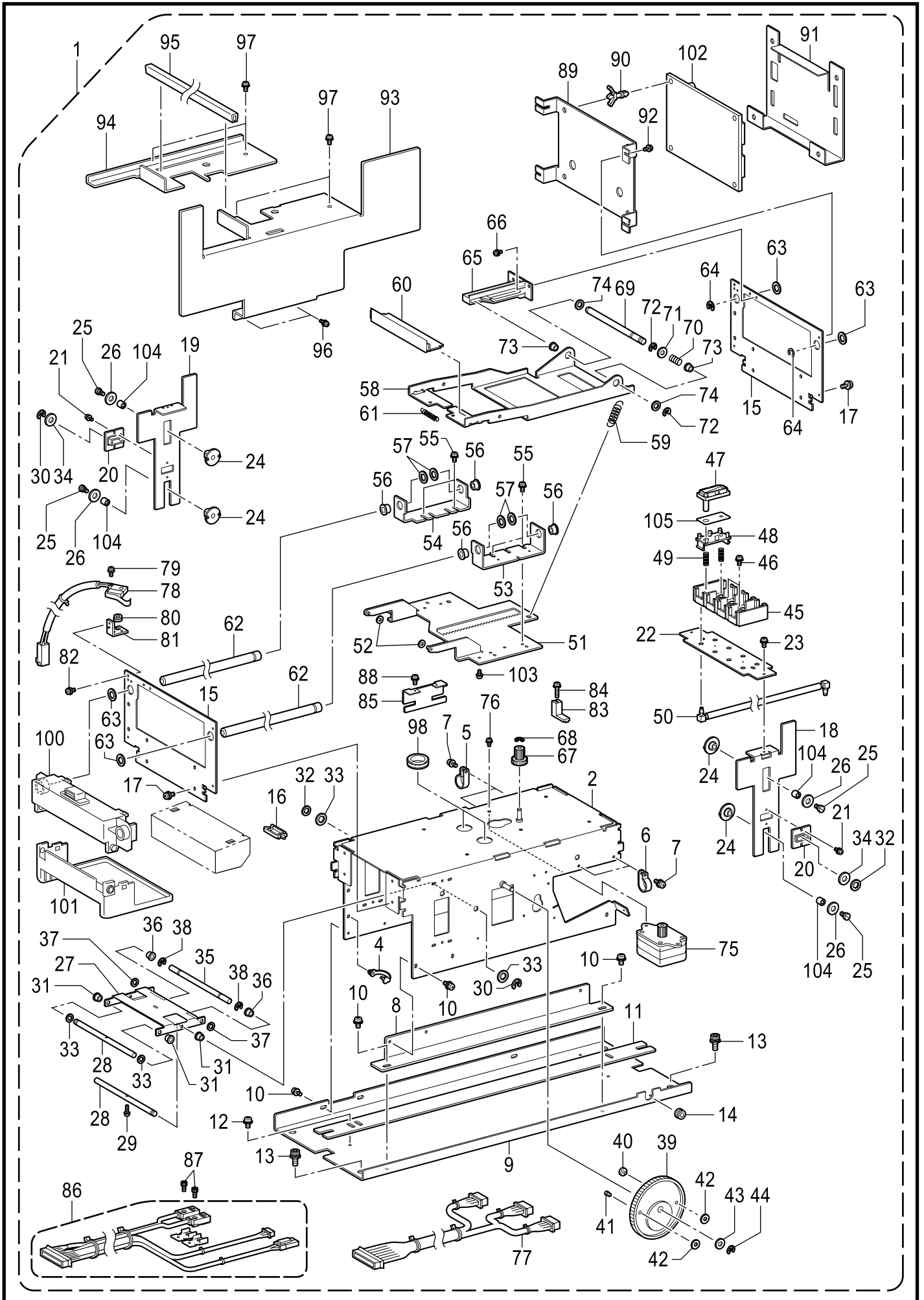

## E1. メンテナンス関係 / Maintenance mechanism

REF.NO	CODE	Q'TY	品名	NAME OF PARTS	RM
51	SA5945001	1	Wラックギヤプレートクミ	W RACK GEAR PLATE SUB ASSY	
52	025050236	2	ヒラザガネチュウ5	WASHER PLAIN M 5	
53	SA5948101	1	スライドブツシユイタR	BUSHING SUPPORT R	
54	SA5949101	1	スライドブツシユイタL	BUSHING SUPPORT L	
55	0A5400806	4	+ナベザクミ4X8DB	SCREW PAN (S/P WASHER) M4X8	
56	SA5950001	4	ムキユウユブツシユ10	OIL FREE BUSHING 10X6	
57	SA5951001	4	CSTメワ12	RETAINING RING CSTW-12	
58	SA5952001	1	Wクドウイタ	W DRIVE PLATE	
59	SA5953001	1	ヒキバネ4.9X20	SPRING EXTENSION 4.9X20	
60	SA9001001	1	Wブレードクミ	WIPER ASSY	
61	SA5957101	1	ヒキバネ3.5X30	SPRING EXTENSION 3.5X30	
62	SA5958001	2	Wガイドシヤフト	W GUIDE SHAFT	
63	SA5959001	4	CSTメワ10	RETANING RING CSTW-10	
64	048070346	2	トメワE7	RETAINING RING E7	
65	SA5960001	1	WLカム	WL POSITIONING CAM	
66	0A5300806	2	+ナベザクミ3X8DB	SCREW PAN (S/P WASHER) M3X8	
67	SA5961001	1	Wアイドルギヤ	WIPER DRIVE IDLE GEAR	
68	048030346	1	トメワE3	RETAINING RING E3	
69	SA5962001	1	WLクドウシヤフト	WL THRUST SHAFT	
70	SA5963001	1	オシバネ8X23	SPRING COMPRESSION 8X23	
71	026060250	1	ヒラザガネミガキ6	WASHER PLAIN M 6	
72	048040346	2	トメワE4	RETAINING RING E4	
73	SA5933001	2	ムキユウユブツシユ6	OIL FREE BUSHING 6X5	
74	XA0199001	2	CSTメワCSTW-8	RETAINING RING,CS8	
75	SA5965001	2	モータークミ	MOTOR SUB ASSY	
76	0A5300806	4	+ナベザクミ3X8DB	SCREW PAN (S/P WASHER) M3X8	
77	SA5489001	1	メンテモーターハネス	HARNESS:MNT MOTOR	
78	SA5492101	1	スイッチABJ363840	SWITCH:ABJ363840	
79	0A5301006	1	+ナベザクミ3X10DB	SCREW PAN (S/P WASHER) M3X10	
80	SA5915001	1	グロメットS	GROMMET	
81	SA5971001	1	スイッチホルダ	SENSOR BRACKET	
82	0A5300806	1	+ナベザクミ3X8DB	SCREW PAN (S/P WASHER) M3X8	
83	SA5972001	1	WLガイド	WL LATERAL SUPPORT	
84	0A4403006	1	+ナベザクミ4X30DA	SCREW PAN (S/P WASHER) M4X30	
85	SA5973001	1	Wドグ	WIPER DOG PLATE	
86	SA5491001	1	メンテセンサクミ	MAINTE SENSOR ASSY	
87	018300836	2	アナボルト3X8	BOLT SOCKET M3X8	
88	0A5401006	2	+ナベザクミ4X10DB	SCREW PAN (S/P WASHER) M4X10	
89	SA5984001	1	メンテキバンホルダ	CIRCUIT BOARD BRACKET	
90	S00554000	4	サポート6NS	SUPPORT, 6NS	
91	SA6198001	1	メンテキバンカバー	MNT PCB COVER	
92	0A5300806	4	+ナベザクミ3X8DB	SCREW PAN (S/P WASHER) M3X8	
93	SA5992001	1	ラツカボウシバンR	MNT TOP COVER RIGHT	
94	SA5993001	1	ラツカボウシバンL	MNT TOP COVER LEFT	
95	SA6199001	1	エッジガードCE-012	EDGE GUARD CE-012	
96	0A5300806	2	+ナベザクミ3X8DB	SCREW PAN (S/P WASHER) M3X8	
97	0A5400806	4	+ナベザクミ4X8DB	SCREW PAN (S/P WASHER) M4X8	
98	S50423000	2	ブツシユTB-1926	BUSHING, TB-1926	
100	SA5966001	1	カセットウエクミ	CASSETTE UPPER SUB ASSY	
101	SA5969001	1	カセットシタ	CASSETTE LOWER	
102	SA5369101	1	メンテナンスキバンクミ	PCB ASSY MAINTENANCE	
103	0A5300806	2	+ナベザクミ3X8DB	SCREW PAN (S/P WASHER) M3X8	
104	SA5396001	4	スペーサ	SPACER	
105	SA4463001	4	キャップスペーサ	CAP SPACER	

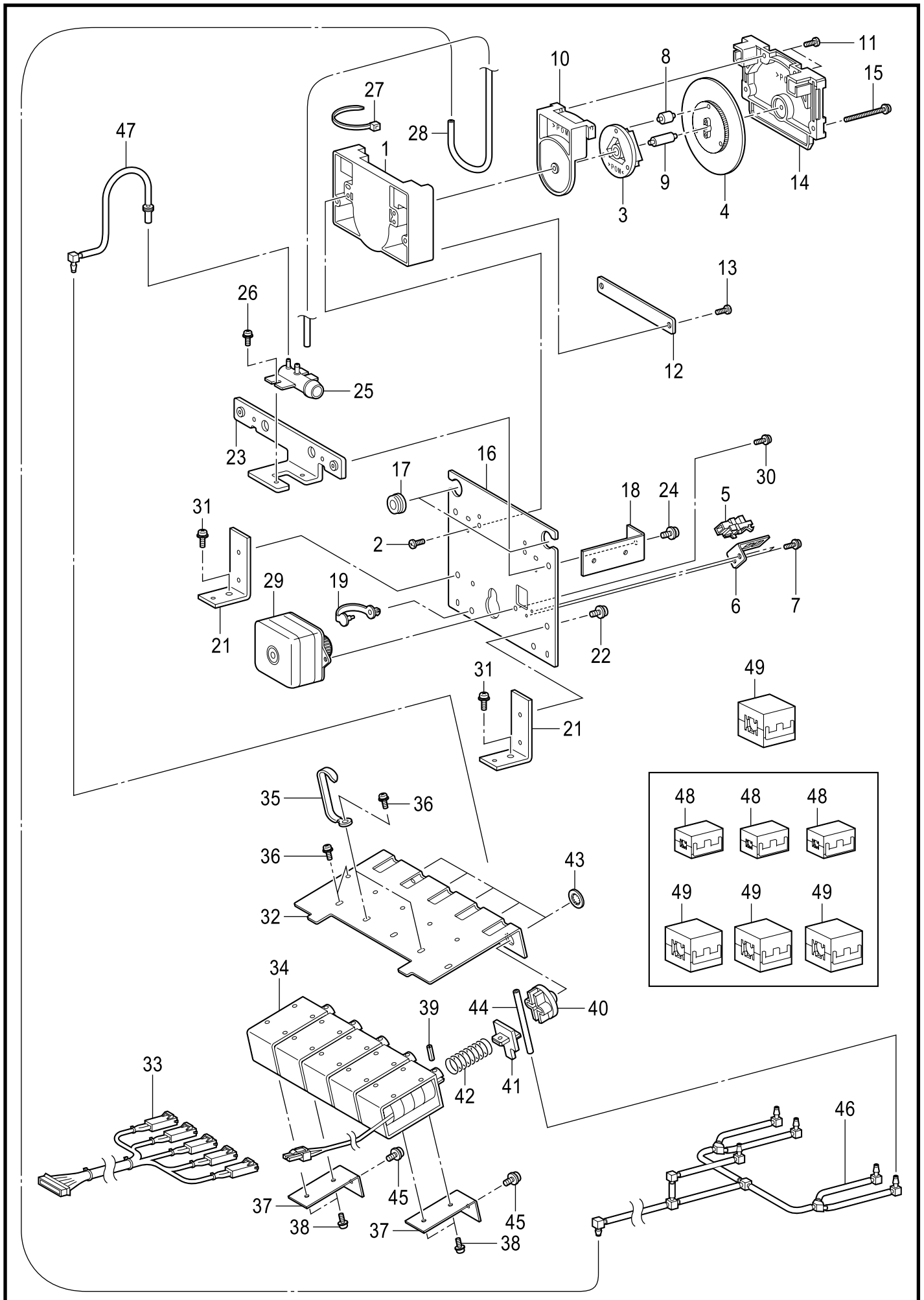

## E2. メンテナンス関係 / Maintenance mechanism

REF.NO	CODE	Q'TY	品名	NAME OF PARTS	RM
1	SA5974001	1	ポンプハウジング	SUCTION PUMP HOUSING	
2	085300816	2	バインドPタイト3X8	TAPTITE BIND P M3X8	
3	SA5975001	1	ポンプロータ	PUMP ROTOR	
4	SA5976001	1	ポンプロータギヤ	ROTATE GEAR	
5	LG2239001	1	PHINTSG-2482A	PHOTO INTERRUPTER:SG-2482A	
6	SA5977001	1	ポンプセンサホルダ	PUMP SENSOR BRACKET	
7	0A5300806	2	+ナベザクミ3X8DB	SCREW PAN (S/P WASHER) M3X8	
8	SA5978001	3	ポンプローラ	ROLLER	
9	SA5979001	1	ポンプロータジク	ROTOR CENTER SHAFT	
10	SA5980001	1	ロータホルダサポート	ROTOR SUPPORT	
11	085300816	2	バインドPタイト3X8	TAPTITE BIND P M3X8	
12	SA5981001	1	ロータホルダストツパ	SUPPORT STOPPER PLATE	
13	085300816	2	バインドPタイト3X8	TAPTITE BIND P M3X8	
14	SA5982001	1	ポンプロータホルダ	ROTOR HOLDER	
15	0A4303506	2	+ナベザクミ3X35DA	SCREW PAN (S/P WASHER) M3X35	
16	SA5983001	1	ポンプホルダ	SUCTION PUMP BRACKET	
17	SA5921001	2	グロメット	GROMMET	
18	SA6335001	1	ソレノイドコティアングル	SOLENOID FIXING ANGLE	
19	SA5916001	2	スピードクランプ	CLAMP	
21	SA6333001	2	ポンプコティアングル	PUMP UNIT FIXING ANGLE	
22	0A5400806	2	+ナベザクミ4X8DB	SCREW PAN (S/P WASHER) M4X8	
23	SA5995001	1	ツギテササエイタ	FITTING SUPPORT BRACKET	
24	0A5400806	2	+ナベザクミ4X8DB	SCREW PAN (S/P WASHER) M4X8	
25	SA5996101	1	ハイエキツギテ	DRAIN PLUG	
26	0A5300806	2	+ナベザクミ3X8DB	SCREW PAN (S/P WASHER) M3X8	
27	SA6003001	1	KIタイ	KI TIE	
28	SA6001001	1	ポンプチューブ	PUMP TUBE	
29	SA5965001	1	モータークミ	MOTOR SUB ASSY	
30	0A5300806	2	+ナベザクミ3X8DB	SCREW PAN (S/P WASHER) M3X8	
31	0A5400806	2	+ナベザクミ4X8DB	SCREW PAN (S/P WASHER) M4X8	
32	SA5986001	1	バルブベースイタ	SOLENOID BASE BRACKET	
33	SA5490001	1	メンテソレノイドハーネス	HARNES:MNT SOL	
34	SA5497001	5	ソレノイドTDS-12EL	SOLENOID:TDS-12EL	
35	SA6155001	2	クリップCS-6U	CLIP:CS-6U	
36	0A5300806	12	+ナベザクミ3X8DB	SCREW PAN (S/P WASHER) M3X8	
37	SA6335001	2	ソレノイドコティアングル	SOLENOID FIXING ANGLE	
38	0A5300806	4	+ナベザクミ3X8DB	SCREW PAN (S/P WASHER) M3X8	
39	047301242	5	スプリングピンAW3	PIN SPRING ROLL AW3	
40	SA5988001	5	プランジャストツパ	PLUNGER STOP	
41	SA5989001	5	プランジャヘッド	PLUNGER HEAD	
42	SA5990001	5	オシバネ14X30	SPRING COMPRESSION 14X30	
43	SA5959001	5	CSTメワ10	RETANING RING CSTW-10	
44	SA6004001	5	キュウインチューブ	SUCTION TUBE	
45	0A5400806	2	+ナベザクミ4X8DB	SCREW PAN (S/P WASHER) M4X8	
46	SA6253001	1	ブンキブラグクミ	BRANCH FITTING ASSY	
47	SA6341001	1	ブレーカチューブ1クミ	BREAKER TUBE ASSY1	
			<北米向>	<For USA and Canada >	
48	S52162000	3	コアNF-65	CORE, NF-65	
49	S52163000	3	コアNF-130	CORE, NF-130	
			<欧州向>	<For Europe only>	
49	S52163000	1	コアNF-130	CORE, NF-130	

F. インク供給 / Ink supply mechanism

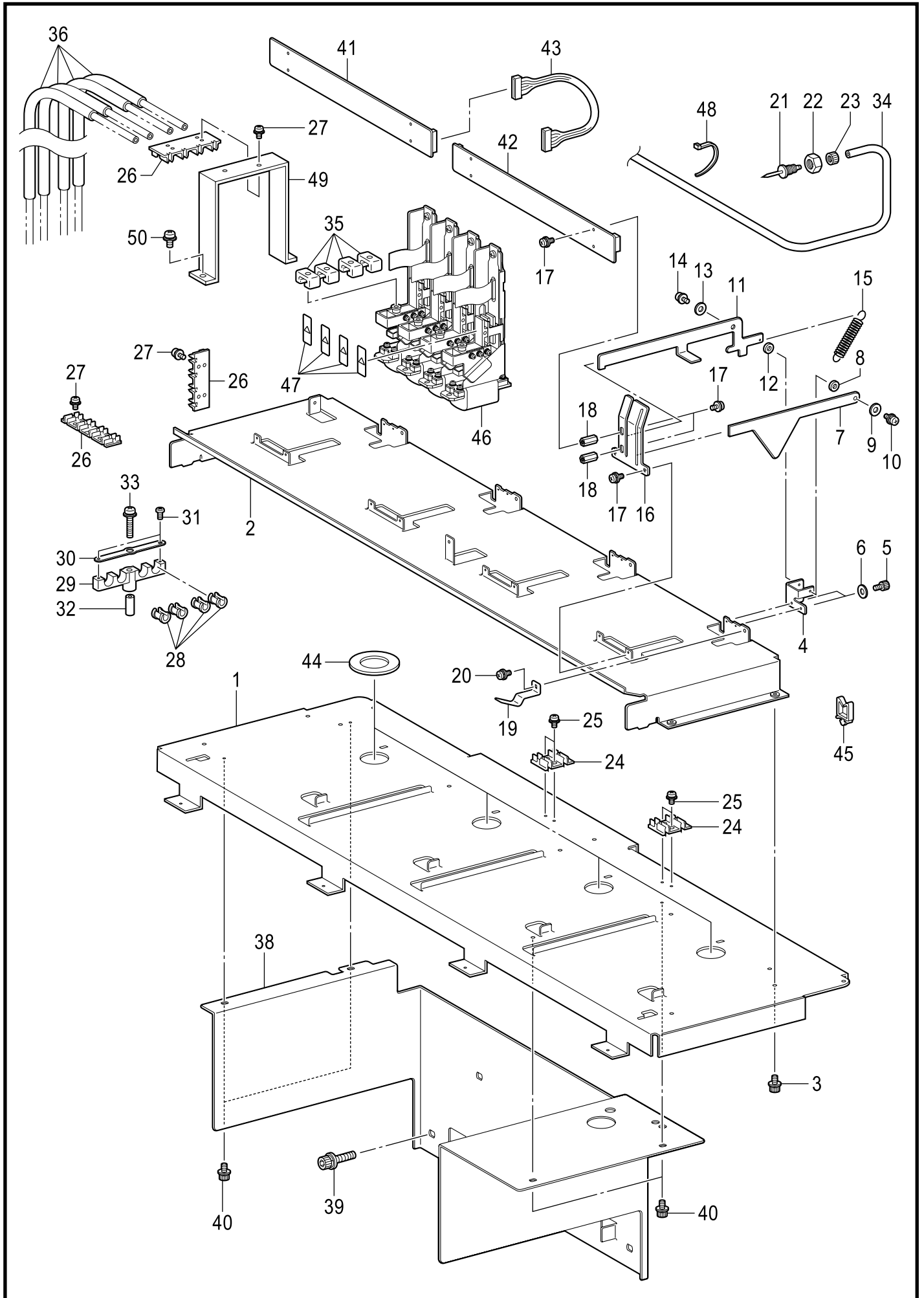



F. インク供給 / Ink supply mechanism

REF.NO	CODE	Q'TY	品名	NAME OF PARTS	RM
1	SA5623001	1	カートリッジドダイ	CARTRIDGE HOLDER PLATE	
2	SA5624001	1	カートリッジホルダ	CARTRIDGE HOLDER	
3	S55479001	9	アナボルトザクミ4X8	BOLT SOCKET (S/P WASHER) M4X8	
4	SA5625001	4	ケンチシテンイタ	FULCRUM POSITION PLATE	
5	018300836	8	アナボルト3X8	BOLT SOCKET M3X8	
6	025030236	8	ヒラザガネチュウ3	WASHER PLAIN M 3	
7	SA5626001	4	ザンリョウケンチイタ	MATERIAL PLATE	
8	SA5484001	4	カラ-3	COLLAR ,3	
9	025050236	4	ヒラザガネチュウ5	WASHER PLAIN M 5	
10	0A5300606	4	+ナベザクミ3X6DB	SCREW PAN (S/P WASHER) M3X6	
11	SA5628101	4	カートリッジケンチイタ	CARTRIDGE PLATE	
12	SA5484001	4	カラ-3	COLLAR ,3	
13	025050236	4	ヒラザガネチュウ5	WASHER PLAIN M 5	
14	0A5300606	4	+ナベザクミ3X6DB	SCREW PAN (S/P WASHER) M3X6	
15	SA5630001	4	ケンチバネ	SPRING	
16	SA5631001	4	ケンチアンナイイタ	DETECTION GUIDE PLATE	
17	0A5300606	24	+ナベザクミ3X6DB	SCREW PAN (S/P WASHER) M3X6	
18	SA5632001	8	スペ-サAS-312	SPACER:AS-312	
19	SA5633001	4	オサエイタバネ	PRESS SPRING	
20	0A5300606	4	+ナベザクミ3X6DB	SCREW PAN (S/P WASHER) M3X6	
21	SA5634001	4	ニードル	NEEDLE	
22	021100206	4	2シュナット10	NUT 2 M10	
23	SA5635001	4	チューブクランプ	TUBE CLAMP	
24	SA5636001	2	チューブホルダショウ	TUBE HOLDER S	
25	0A5300606	4	+ナベザクミ3X6DB	SCREW PAN (S/P WASHER) M3X6	
26	SA5637001	3	チューブホルダ	TUBE HOLDER	
27	0A5300606	6	+ナベザクミ3X6DB	SCREW PAN (S/P WASHER) M3X6	
28	SA5638001	4	チューブホルダマルガタ	ROUND TUBE HOLDER	
29	SA5639001	1	チューブホルダシタ	TUBE HOLDER LOW	
30	SA5640001	1	チューブホルダウエ	TUBE HOLDER UPPER	
31	037300815	2	Vナベタツピン3X8	TAPPING SCREW PAN V M3X8	
32	SA5641001	1	スペ-サ4X8X25	SPACER 4X8X25	
33	0A5403006	1	+ナベザクミ4X30DB	SCREW PAN (S/P WASHER) M4X30	
34	SA5642001	4	チューブ	TUBE	
35	SA5643001	4	チューブコネクタ	TUBE CONNECTOR	
36	SA5644001	4	チューブガード	TUBE GUARD	
38	SA5493001	1	ホルダホキヨウイタ	HOLDER PLATE	
39	S47269001	6	アナボルトザクミ6X20	BOLT, SOCKET (S/P WASHER)M6X20	
40	S55479001	4	アナボルトザクミ4X8	BOLT SOCKET (S/P WASHER) M4X8	
41	SA5365101	1	インクセンサAキバンクミ	INK SENSOR A PCB ASSY	
42	SA5367101	1	インクセンサBキバンクミ	INK SENSOR B PCB ASSY	
43	SA5390001	1	インクセンサハーネス	HARNESS:INK SENSOR	
44	SA5469001	4	フェルト	FELT	
45	S43275000	3	コードクランプWS2NS	CORD CLAMP, WS2NS	
46	SA5846201	4	プリントヘッド	PRINT HEAD	
47	SA5884001	4	コウオンラベル	HIGH TEMP LABEL	
48	S04159000	1	バンド1M	BAND, 1M	
49	SA5459001	1	チューブササエイタ	TUBE SUPPORT PLATE	
50	0A5401006	2	+ナベザクミ4X10DB	SCREW PAN (S/P WASHER) M4X10	

H. 廃液関係 / Waste ink mechanism

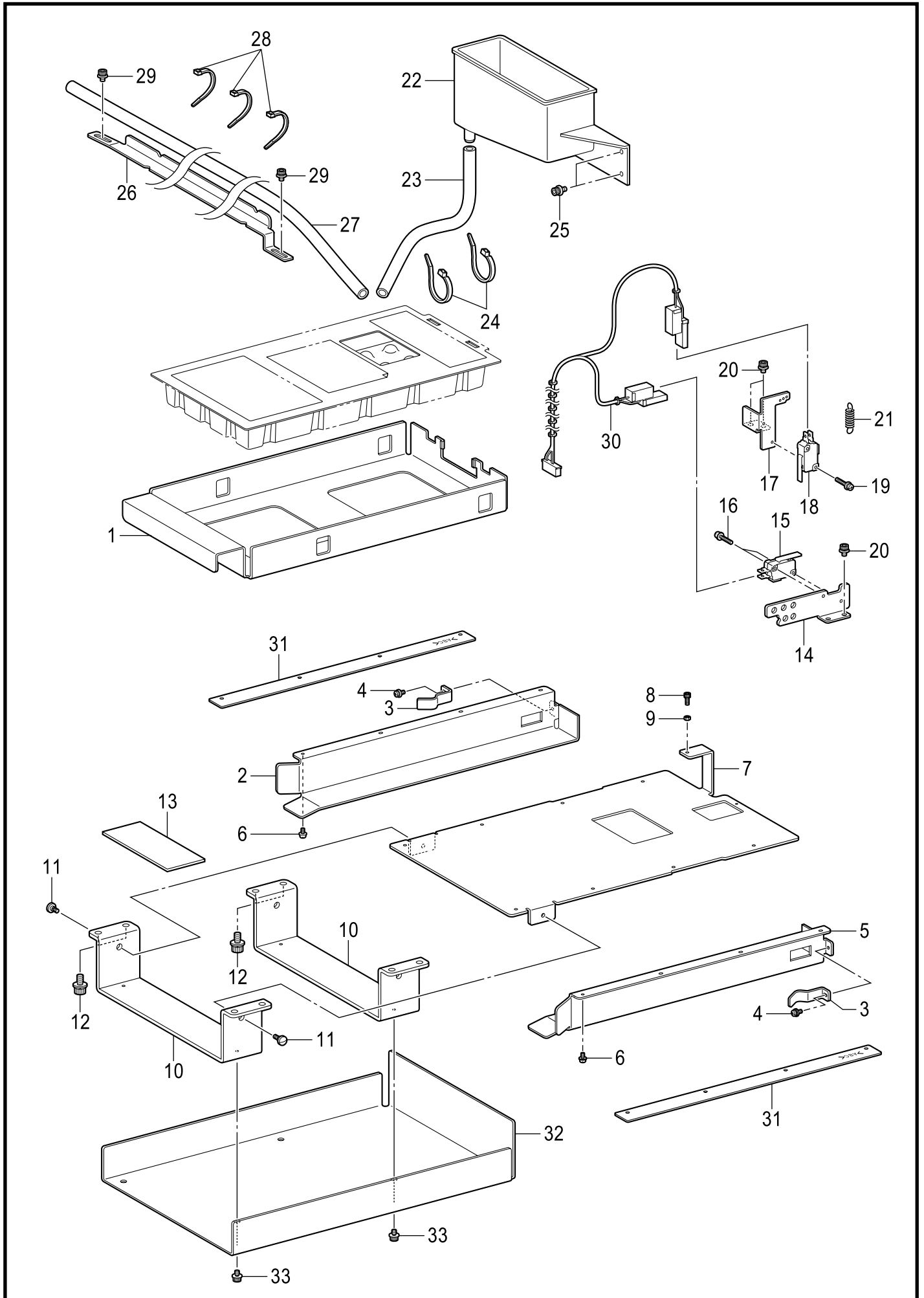

## H. 廃液関係 / Waste ink mechanism

REF.NO	CODE	Q'TY	品名	NAME OF PARTS	RM
1	SA5645001	1	ハイエキボックス	WASTE CARTRIDGE TRAY	
2	SA5646001	1	ハイエキアンナイR	WASTE INK GUIDE R	
3	SA5633001	2	オサエイタバネ	PRESS SPRING	
4	0A5300606	2	+ナベザクミ3X6DB	SCREW PAN (S/P WASHER) M3X6	
5	SA5648001	1	ハイエキアンナイL	WASTE INK GUIDE L	
6	0A5300606	8	+ナベザクミ3X6DB	SCREW PAN (S/P WASHER) M3X6	
7	SA5649001	1	ハイエキトリツケイタ	WASTE INK PLATE	
8	018300836	1	アナボルト3X8	BOLT SOCKET M3X8	
9	021300206	1	2シュナット3	NUT 2 M3	
10	SA5650001	2	ハイエキガード	WASTE INK GUARD	
11	S25283001	2	ダンネジ4	SHOULDER SCREW, M4	
12	S42446001	8	アナボルトザクミ6X14	BOLT SOCKET (S/P WASHER)M6X14	
13	SA5651001	1	フェルト	FELT	
14	SA5652001	1	ハイエキセンサステ-A	WASTE INK STAY A	
15	SA5653001	1	マイクロスイッチ	MICRO SWITCH	
16	0A5301606	2	+ナベザクミ3X16DB	SCREW PAN (S/P WASHER) M3X14	
17	SA5654001	1	ハイエキセンサステ-B	WASTE INK STAY B	
18	SA5653001	1	マイクロスイッチ	MICRO SWITCH	
19	0A5301606	2	+ナベザクミ3X16DB	SCREW PAN (S/P WASHER) M3X14	
20	S55479001	4	アナボルトザクミ4X8	BOLT SOCKET (S/P WASHER) M4X8	
21	SA5656001	1	ハイエキバネ	SPRING	
22	SA5657001	1	フラッシングウケ	FLASH PLATE	
23	SA5658001	1	フラッシングチューブ	FLASH INK TUBE	
24	S04159000	2	バンド1M	BAND, 1M	
25	S55479001	2	アナボルトザクミ4X8	BOLT SOCKET (S/P WASHER) M4X8	
26	SA5660001	1	ハイエキチューブウケ	WASTE INK TUBE PLATE	
27	SA5661001	1	ハイエキチューブ	WASTE INK TUBE	
28	S04159000	3	バンド1M	BAND, 1M	
29	S55479001	2	アナボルトザクミ4X8	BOLT SOCKET (S/P WASHER) M4X8	
30	SA5398001	1	ハイエキハーネス	HARNES: DRAIN	
31	SA5586001	2	ハイエキアンナイイタ	WASTE INK GUIDE PLATE	
32	SA6008001	1	ハイエキカバー	WASTE INK COVER	
33	S55479001	4	アナボルトザクミ4X8	BOLT SOCKET (S/P WASHER) M4X8	

J1 . コントロールボックス関係 / Control box mechanism

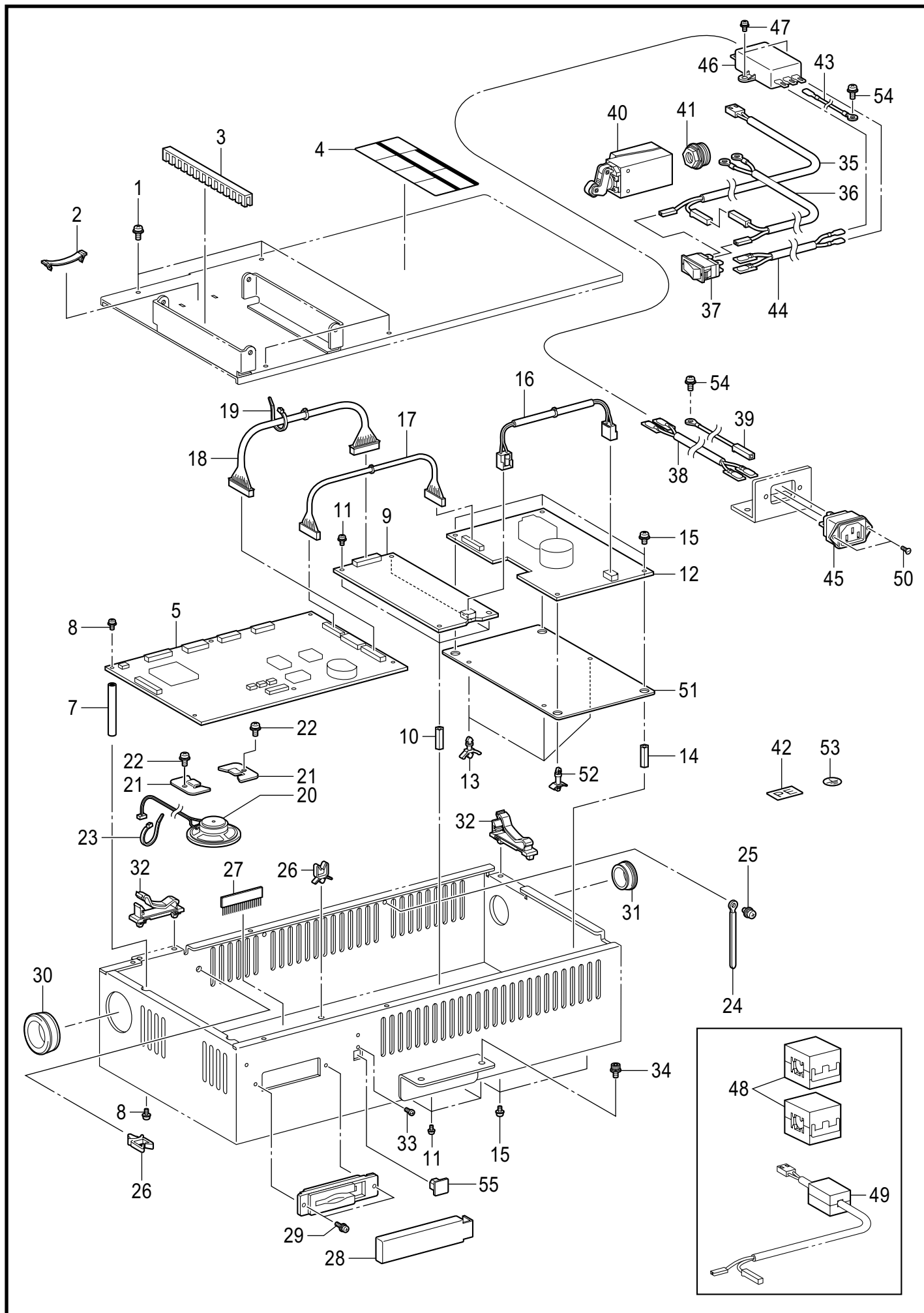

J1. コントロールボックス関係 / Control box mechanism

REF.NO	CODE	Q'TY	品名	NAME OF PARTS	RM
1	0A5400806	4	+ナベザクミ4X8DB	SCREW PAN (S/P WASHER) M4X8	
2	SA6154001	1	クランプFCR-35VO	CLAMP:FCR-35VO	
3	SA5761001	1	グロメットCSG-016	GROMMET:CSG-016	
4	J04115001	1	ラベルカンデン6カコク	LABEL, ELEC. SHOCK 6 LANG.	
5	SA5343201	1	メインキバンクミ	MAIN PCB ASSY	
7	SA6031001	6	スペ-サAP-50	SPACER:AP-50	
8	0A5300606	12	+ナベザクミ3X6DB	SCREW PAN (S/P WASHER) M3X6	
9	SA6329101	1	メインヘッドデンゲンクミUS	MAIN HEAD POWER SUPPLY ASSY US	
10	SA7914001	4	カラ-ASF-320	COLLAR:ASF-320	
11	0A5300606	8	+ナベザクミ3X6DB	SCREW PAN (S/P WASHER) M3X6	
12	SA6330101	1	メインPMデンゲンクミ115V	MAIN PM POWER SUPPLY ASSY 115V	
13	S00554000	3	サポ-ト6NS	SUPPORT, 6NS	
14	SA7913001	3	スペ-サ4SP-20	SPACER:4SP-20	
15	0A4400606	6	+ナベザクミ4X6DA	SCREW, PAN (S/P WASHER) M4X6	
16	SA5385101	1	AML-BHMハーネス	HARNESS:AML-BHM	
17	SA5386001	1	AMLデンゲンハーネス	HARNESS:AML POWER	
18	SA5387001	1	BHMデンゲンハーネス	HARNESS:BHM POWER	
19	S04159000	1	バンド1M	BAND, 1M	
20	LG4618001	1	スピー-カユニットMINIFB	SPEAKER UNIT MINIFB	
21	SA5470001	2	スピー-カ-トリツケイタ	SPEAKER SUPPORT	
22	0A5400806	2	+ナベザクミ4X8DB	SCREW PAN (S/P WASHER) M4X8	
23	S04159000	1	バンド1M	BAND, 1M	
24	SA6155001	1	クリップCS-6U	CLIP:CS-6U	
25	0A5400806	1	+ナベザクミ4X8DB	SCREW PAN (S/P WASHER) M4X8	
26	S43275000	2	コードクランプWS2NS	CORD CLAMP, WS2NS	
27	SA6365001	1	ジョデンブラシSFA	BRUSH:ELEC BAR SFA 50MM	
28	SA3573001	1	CFキャップ	CF CAP	
29	0A5301006	2	+ナベザクミ3X10DB	SCREW PAN (S/P WASHER) M3X10	
30	S43274000	1	ブツシュTB-2938	BUSH, TB-2938	
31	S50423000	1	ブツシュTB-1926	BUSHING, TB-1926	
32	SA6054001	2	クランプB-4S	CLAMP:B-4S	
33	062300816	1	ナベコ3X8	SCREW PAN M3X8	
34	S55479001	6	アナボルトザクミ4X8	BOLT SOCKET (S/P WASHER) M4X8	
35	SA5384001	1	ACデンゲンハーネス	HARNESS:AC POWER	
36	SA5383101	1	カバースイッチハーネス	HARNESS:COVER SW	
37	SA6040001	1	スイッチAJ8201BF	SWITCH:AJ8201BF	
38	SA5382001	1	インレットハーネス	HARNESS:INLET	
39	SA5381001	1	ア-スセン150	GROUND WIRE:150	
40	SA6145001	1	スイッチAZD1000	SWITCH:AZD1000	
41	SA6144001	1	コネクタAZD1830	CONNECTOR:AZD1830	
42	S37059001	1	PEマーク	LABEL, PE	
43	SA6268001	1	ア-スセン200	GRONUD WIRE:200	
44	SA6269001	1	ACスイッチハーネス	HARNESS:AC SWITCH	
45	SA6270001	1	インレットAP-300-2B2	INLET:AP-300-2B2	
46	SA6271001	1	EMCフィルタZCB2206	EMC FILTER:ZCB2206-11S	
47	0A5300806	2	+ナベザクミ3X8DB	SCREW PAN (S/P WASHER) M3X8	
50	S06696004	2	サラコネジ3X6	SCREW, FLAT M3X6	
51	SA6090001	1	キバンシタイタ	PLATE UNDER BOARD	
52	SA7918001	1	サポ-トKGLS-12S	SUPPORT:KGLS-12S	
53	S37060001	1	ア-スマーク	LABEL, GROUNDING	
54	0A5400806	2	+ナベザクミ4X8DB	SCREW PAN (S/P WASHER) M4X8	
55	SB0442001	1	USBコネクタカバー	USB CONNECTOR COVER	
			<北米向>	<For USA & Canada >	
48	S52163000	2	コアNF-130	CORE, NF-130	
49	S52162000	1	コアNF-65	CORE, NF-65	

J2 . コントロールボックス関係 (欧州向) / Control box mechanism (For Europe only)

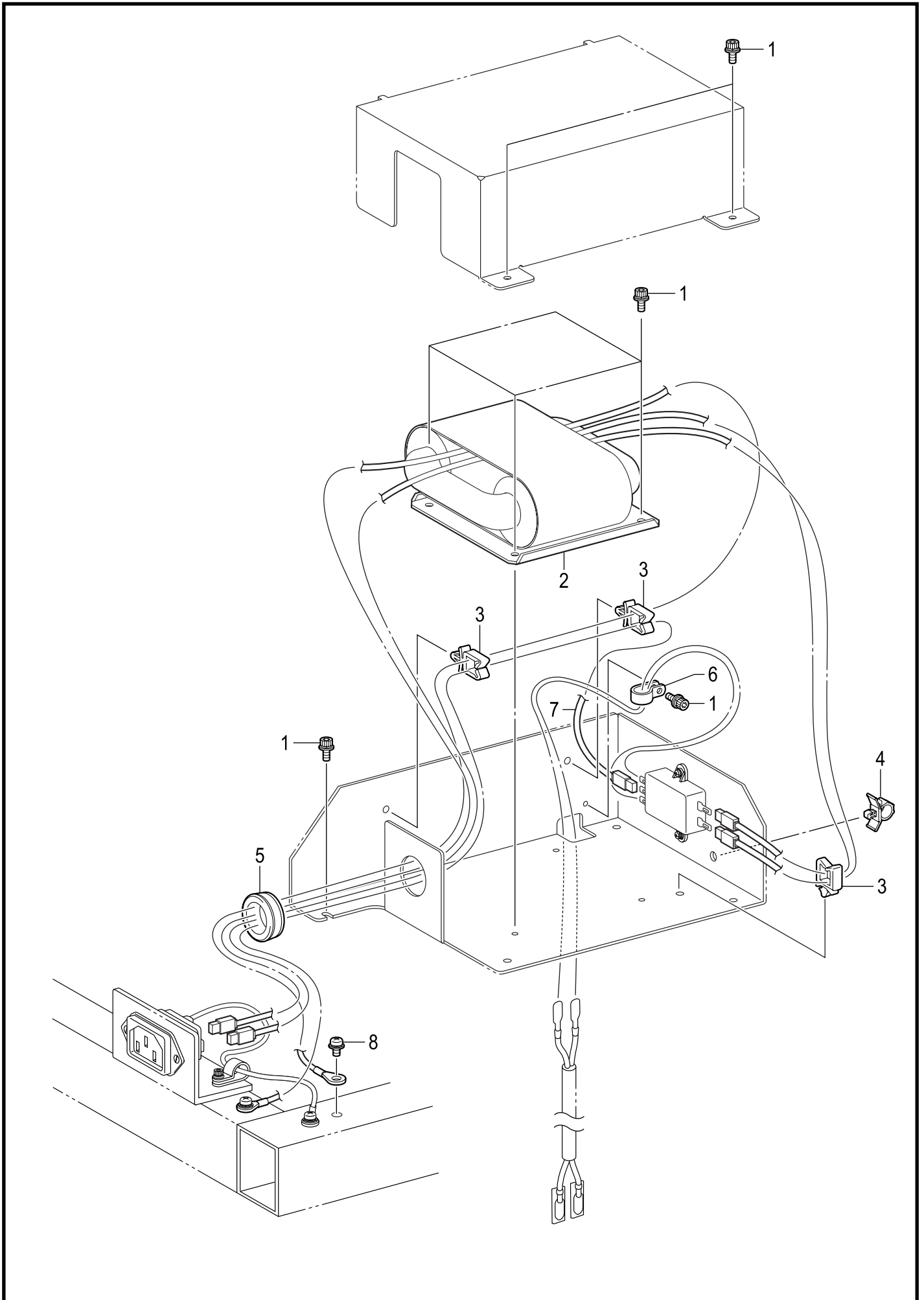

J2. コントロールボックス関係（欧州向） / Control box mechanism (For Europe only)

REF.NO	CODE	Q'TY	品名	NAME OF PARTS	RM
1	S55479001	9	アナボルトザクミ4X8	BOLT SOCKET (S/P WASHER) M4X8	
2	SA9221001	1	ヘンカントランス230V	TRANSFORMER 230V	
3	S43275000	3	コードクランプLWS2NS	CORD CLAMP LWS2NS	
4	S17022000	1	CKSクランプ10-H	CORD CLAMP, 10-H	
5	S50423000	1	ブツシュTB-1926	BUSHING, TB-1926	
6	S00480000	1	コードホルダ#5	CORD HOLDER 5N	
7	SA9219001	1	ア-スセン340	GROUND WIRE:340	
8	0A5400806	1	+ナベザクミ4X8DB	SCREW PAN (S/P WASHER) M4X8	

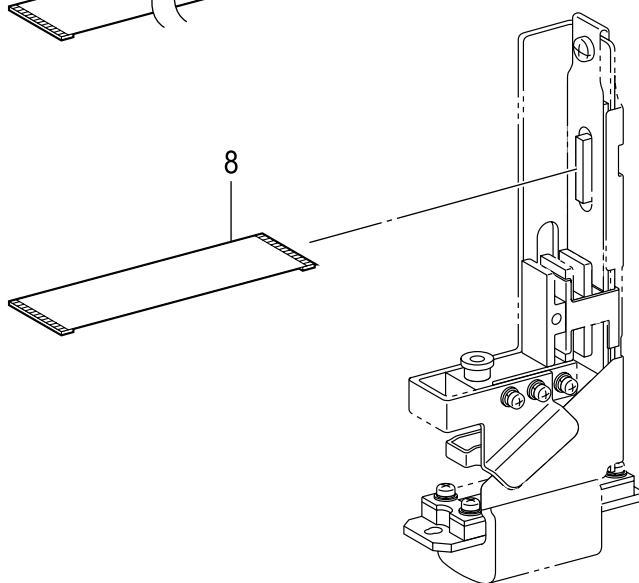
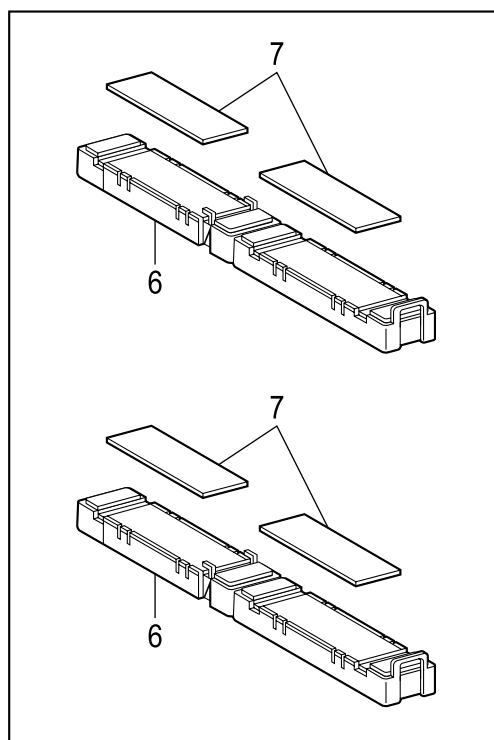
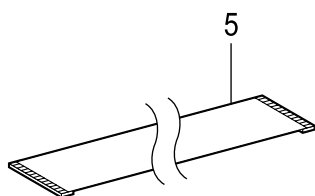
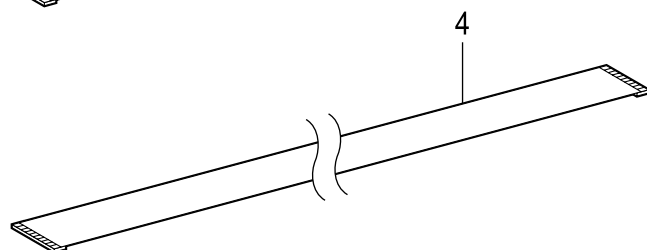
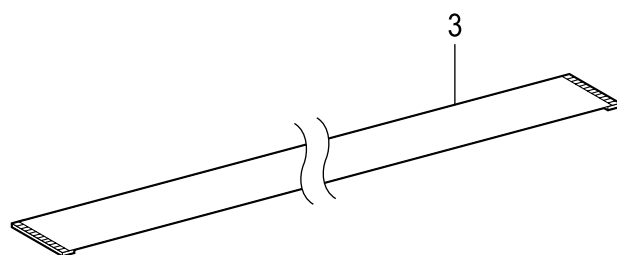
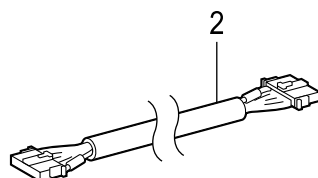
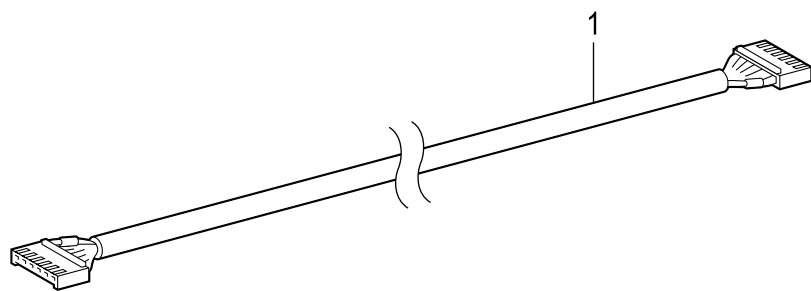



K. 電装品関係 / Power supply equipment mechanism

REF.NO	CODE	Q'TY	品名	NAME OF PARTS	RM
1	SA5380001	1	メンテツウシンハーネス	HARNES:MINTENANCE COM	
2	SA5389001	1	インクツウシンハーネス	HARNES:INK COM	
3	SA5391001	1	キャリッジシンゴウFFC	FFC:CARRIAGE SIGNAL	
4	SA5392001	1	ヘッドデンゲンFFC	FFC:HEAD POWER	
5	SA5394001	1	パネルFFC	FFC:PANEL	
			<日本、欧州向>	<For Japan and Europe>	
6	SA8913101	2	フェライトコア ZCAT6819	FERRITE CORE:ZCAT6819-5230D	
7	SA8981001	4	スキマパッド	PAD	
			<補給用部品>	<For Supply parts>	
8	SA5393001	1	ヘッドFFC	FFC:HEAD	

L . 操作パネル関係 / Operation panel mechanism

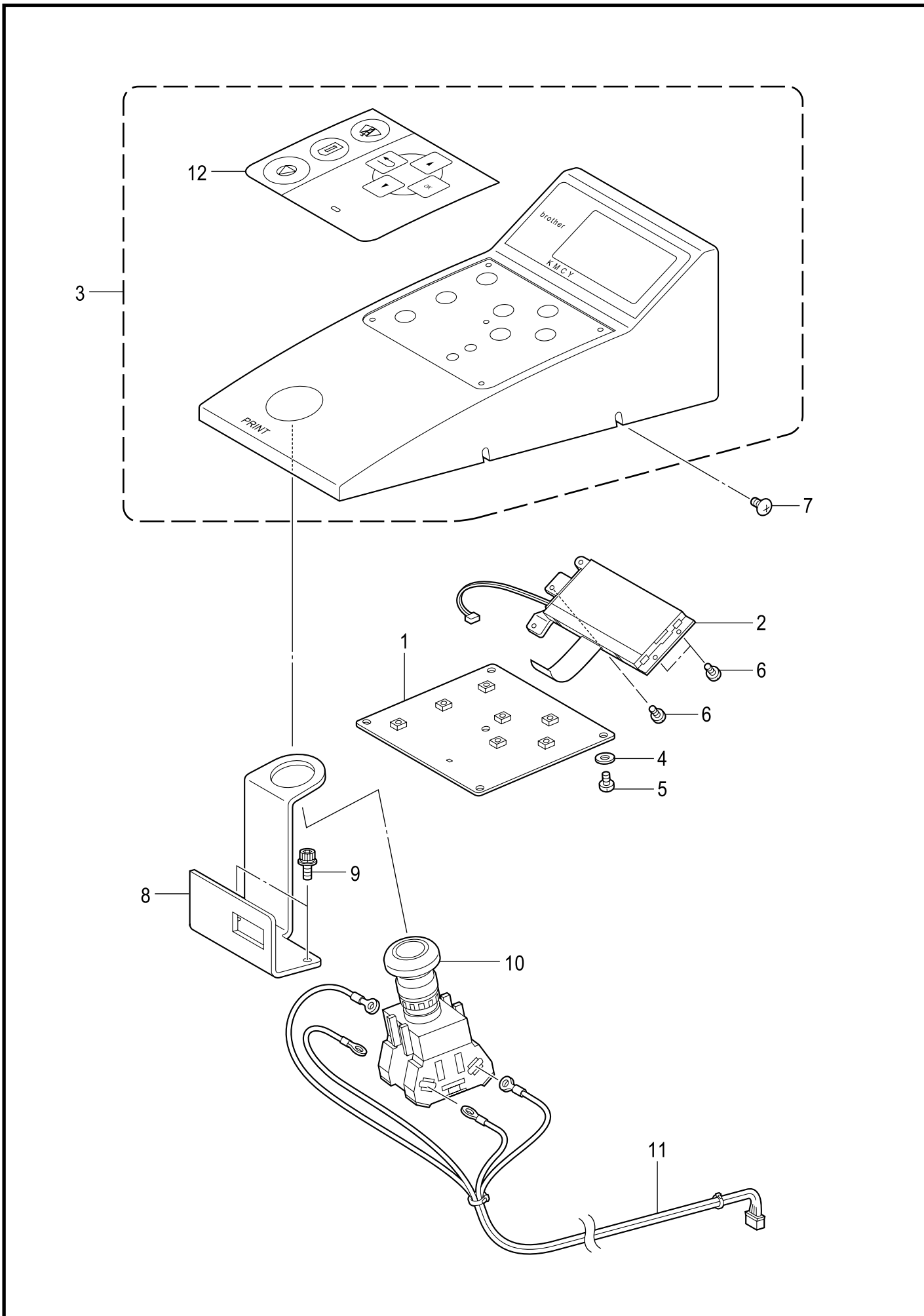

## L. 操作パネル関係 / Operation panel mechanism

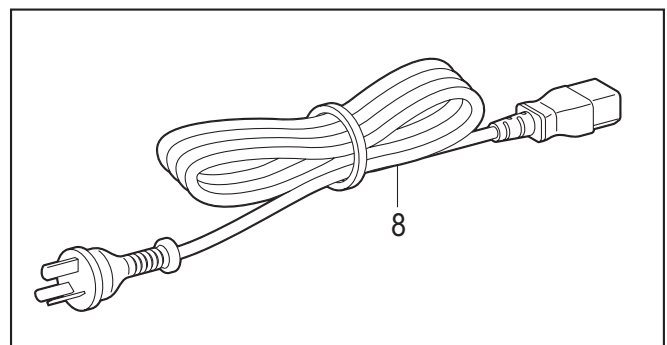
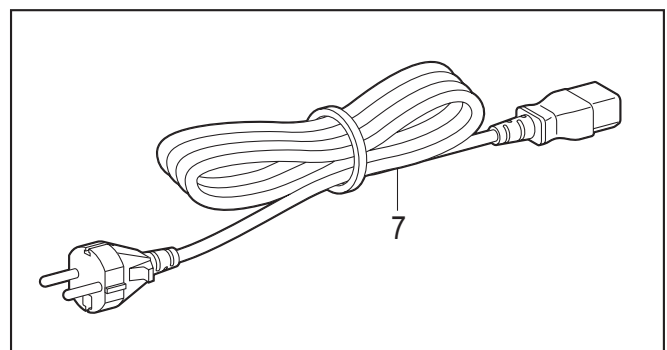
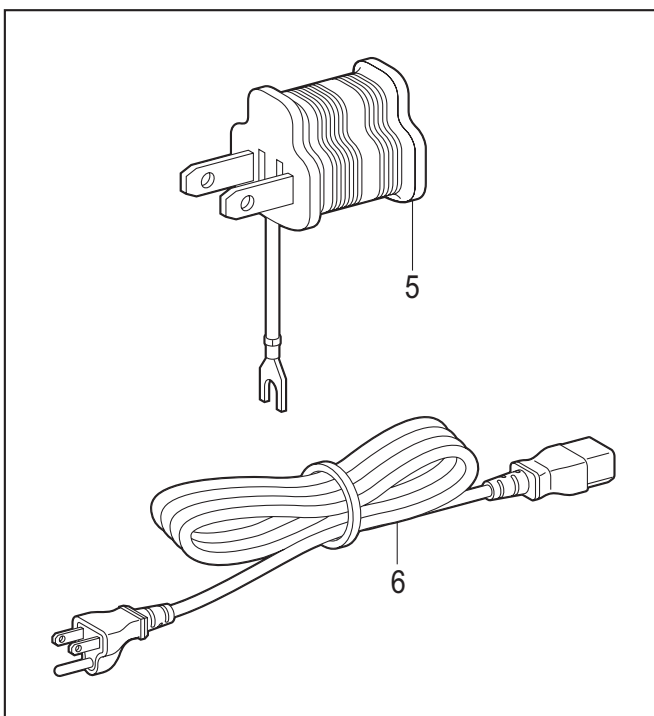
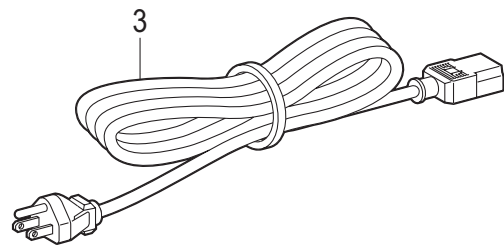
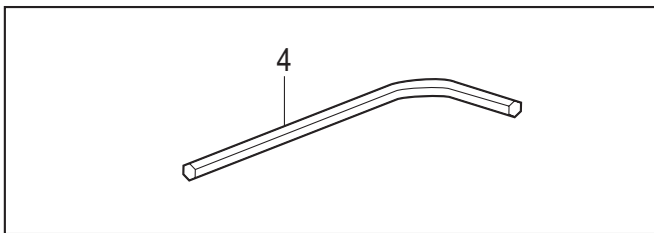
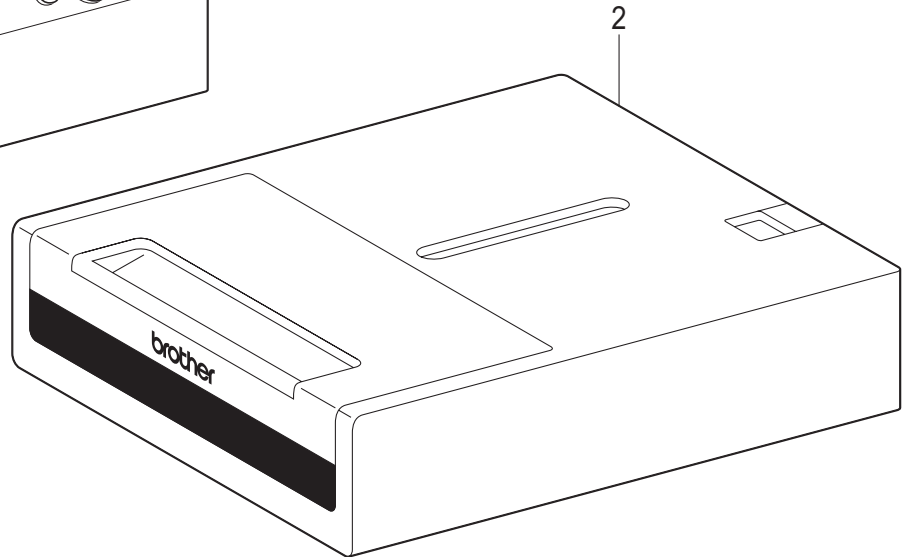
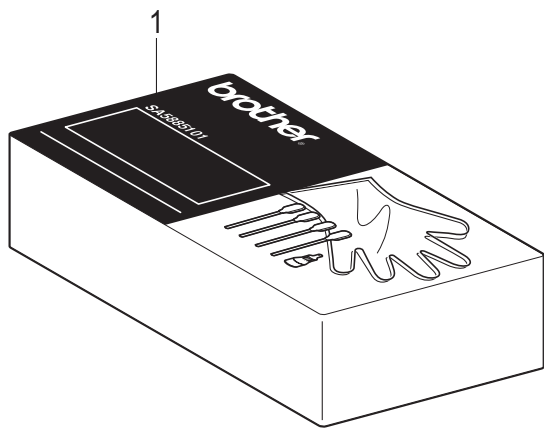

REF.NO	CODE	Q'TY	品名	NAME OF PARTS	RM
1	SA5357101	1	パネルキバンクミ	PANEL PCB ASSY	
2	SA5360001	1	ニトウシキドウコンバンクミ	LIGHT PLATE ASSY	
3	SA5627101	1	パネルカバークミ	PANEL COVER ASSY	
4	026030135	5	ヒラザガネコガタ3	WASHER PLAIN S 3	
5	083300615	5	ナベPタイト3X6	TAPTITE PAN P M3X6	
6	085300816	3	バインドPタイト3X8	TAPTITE BIND P M3X8	
7	060400616	4	バインド4X6	SCREW TRUSS M4X6	
8	SA5463001	1	スイッチトリツケイタ	SWITCH ATTACHMENT PLATE	
9	S55479001	2	アナボルトザクミ4X8	BOLT SOCKET (S/P WASHER) M4X8	
10	SA5400001	1	スイッチHW1L	SWITCH:HW1L-M410Q1G-TK2318	
11	SA5388001	1	プリントスイッチハーネス	HARNES:PRINT SWITCH	
12	SA5511101	1	パネルシート	PANEL SHEET	





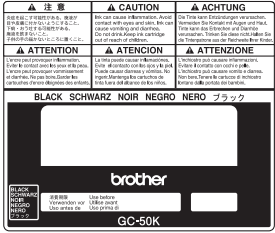
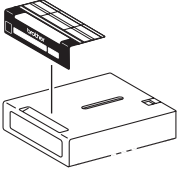
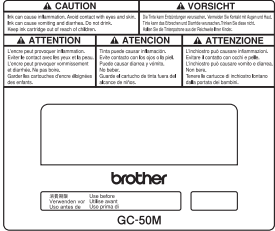
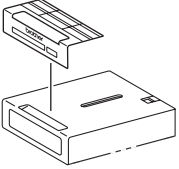
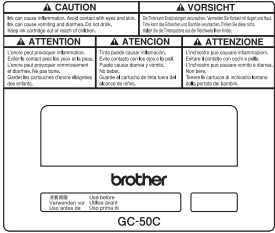
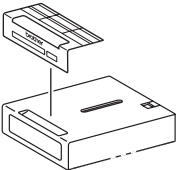
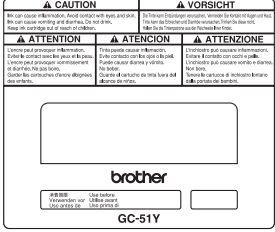
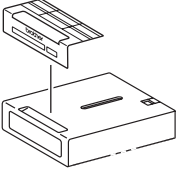

## Z. 付属品関係 / Accessories

REF.NO	CODE	Q'TY	品名	NAME OF PARTS	RM
1	SA5885201	1	ノズルクリーニングキット	NOZZLE CLEANING KIT	
2	SA5896201	4	フィルタカートリッジ	FILTER CARTRIDGE	
3	SA6452001	1	<北米向> ACコードUL/CSA	<For USA and Canada > AC CORD, UL/CSA	
4	142721001	1	<日本、欧州向> 6カクボウスパナ3	<For Japan and Europe> HEXAGONAL WRENCH, 3	
5	SA9223001	1	<日本向> ACヘンカンプラグ	<For Japan only> AC PLUG ADAPTER	
6	SB0001001	1	ACコードUL/CSA/PSE	AC CORD UL/CSA/PSE	
7	SA9222001	1	<欧州向> ACコードEUR	<For Europe only> AC CORD EUR	
8	SA8838001	1	<豪州向> ACコードAU	<For Australia and New Zealand> AC CORD AU	

# Wa1. 警告ラベル / Warning labels

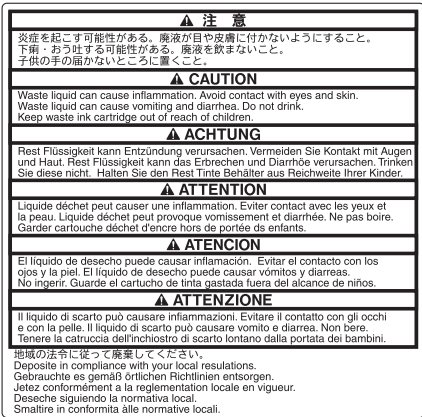
警告ラベル / Warning labels	品名 / Name of parts	Size(mm)	Code
 <p><b>⚠ 危険</b> ⚠ 危険  <b>⚠ DANGER</b> ⚠ GEFAHR ⚠ DANGER ⚠ PELIGRO          High voltage parts are present. Turn off main switch and wait 5 minutes before opening this cover.          Hochspannung Verletzungsgefahr! Bitte schalten sie den Hauptschalter aus und warten sie 5 minuten, bevor diese abdeckung offnen.          Un voltage non adapte provoque des blessures. Eteindre l'interrupteur et attendre 5 minutes avant d'ouvrir le capot.          Un voltaje inadecuado puede provocar las heridas. Apagar el interruptor principal y esperar 5 minutos antes de abrir esta cubierta.</p>	ラベル感電6ヶ国 Label, elec. shock 6 lang	50 X 118	J04115-001
 <p><b>⚠ 警告</b> ⚠ WARNING ⚠ WARNUNG          Needle inside can cause injury. Do not put hands in ink cartridge slot.          Nadel im inneren kann Verletzungen verursachen. Führen Sie die Hände nicht in den Kartuschen Schlitz ein.  <b>⚠ AVERTISSEMENT</b> ⚠ AVISO ⚠ AVVERTENZE          L'aguiille à l'intérieur peut blesser. Ne pas mettre la main dans l'emplacement de cartouche.          La aguja interior puede causar heridas. No ponga las manos en la ranura de cartucho de tinta.          La presenza di aghi può causare infortuni. Non infirare le mani nella fessura delle cartucce.</p>	針注意ラベル Needle caution label	250 X 51	SA6316-301
 <p><b>⚠ 注意</b>          プラテンやTシャツトレイとカバーとの間に手をはさみ、けがをする。印刷中はプラテンから手を離すこと。  <b>⚠ CAUTION</b>          Moving platen, T-shirt tray and covers can cause bodily injury. Keep hands off platen while printing.  <b>⚠ ACHTUNG</b>          Druckplatte, T-Shirt-Ablage und Abdeckungen können körperliche Verletzungen verursachen. Halten Sie die Hände von der Auflage während des Druckvorganges fern.  <b>⚠ ATTENTION</b>          Déplacement du plateau, chargeur T-shirt et couvercle peut blesser le corps. Garder les mains éloignées lors de l'impression.  <b>⚠ ATENCION</b>          Moviendo la placa, la bandeja de camiseta y las cubiertas pueden causar una herida personal. Retire las manos de la placa durante la impresión.  <b>⚠ ATTENZIONE</b>          Tavoleta mobile, il ripiano per la T-shirt ed il carter potrebbero causare infortuni. Tenere le mani lontane dalla tavoleta durante la stampa.</p>	プラテン注意ラベル Platen caution label	180 X 100	SA6317-201
 	カートリッジラベル K Cartridge label K	146 X 123.7	SA5772-201
 	カートリッジラベル M Cartridge label M	146 X 123.7	SA5806-201
 	カートリッジラベル C Cartridge label C	146 X 123.7	SA5825-201
 	カートリッジラベル Y Cartridge label Y	146 X 123.7	SA8032-201

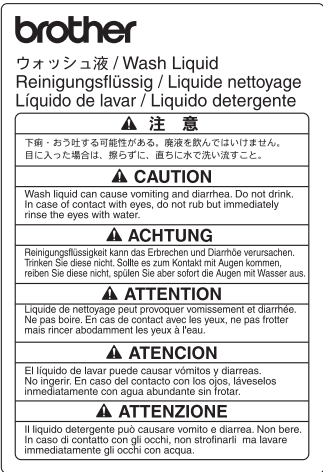
## Wa2. 警告ラベル / Warning labels

警告ラベル / Warning labels	品名 / Name of parts	Size (mm)	Code
	<p>廃液注意ラベル Waste ink caution label</p>	<p>130 X 127.5</p>	<p>SA6318-301</p>
	<p>高温ラベル High temp label</p>	<p>20 X 10</p>	<p>SA5884-001</p>
	<p>コーションラベル Caution label</p>	<p>60 X 10</p>	<p>SA5783-201</p>
	<p>洗浄液ラベル Wash liquid label</p>	<p>55 X 80</p>	<p>SA6322-301</p>
	<p>ワーニングマーク Injury mark</p>	<p>L=25</p>	<p>SA9957-002</p>

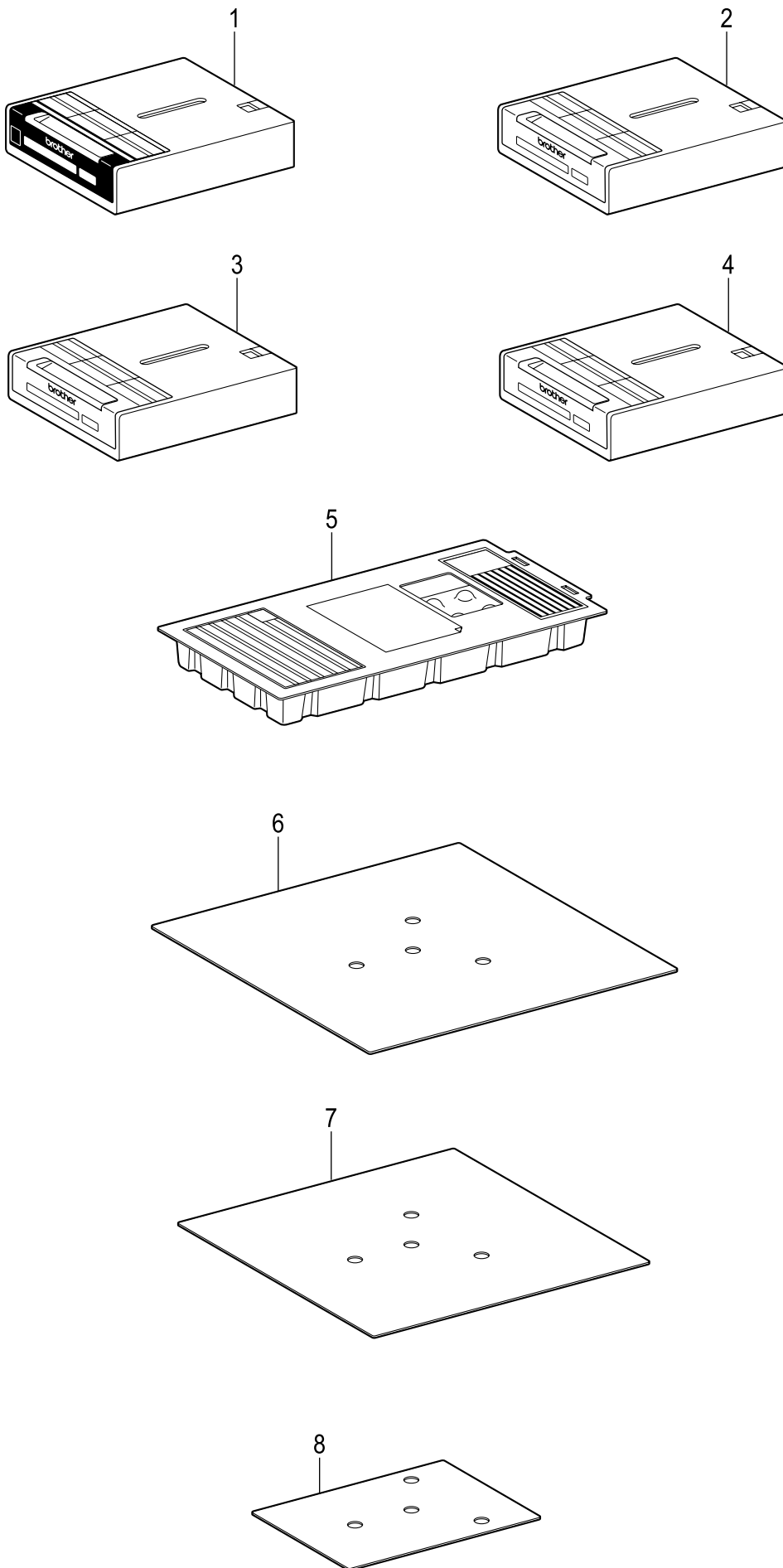



## Co. 消耗品 / Consumables

REF.NO	CODE	Q'TY	品名	NAME OF PARTS	RM
1	GC-50K	1	ブラックインクカートリッジ	BLACK INK CARTRIGE	
2	GC-50M	1	マゼンタインクカートリッジ	MAGENTA INK CARTRIGE	
3	GC-50C	1	シアンインクカートリッジ	CYAN INK CARTRIGE	
4	GC-51Y	1	イエローインクカートリッジ	YELLOW INK CARTRIGE	
5	SA5629201	1	ハイエキインクカートリッジクミ	WASTE INK CARTRIDGE ASSY	
6	SA5620201	1	プラテンシート	PLATEN SHEET	
7	SA6401201	1	プラテンシートS	PLATEN SHEET S	
8	SA8211101	1	プラテンシートSS	PLATEN SHEET SS	

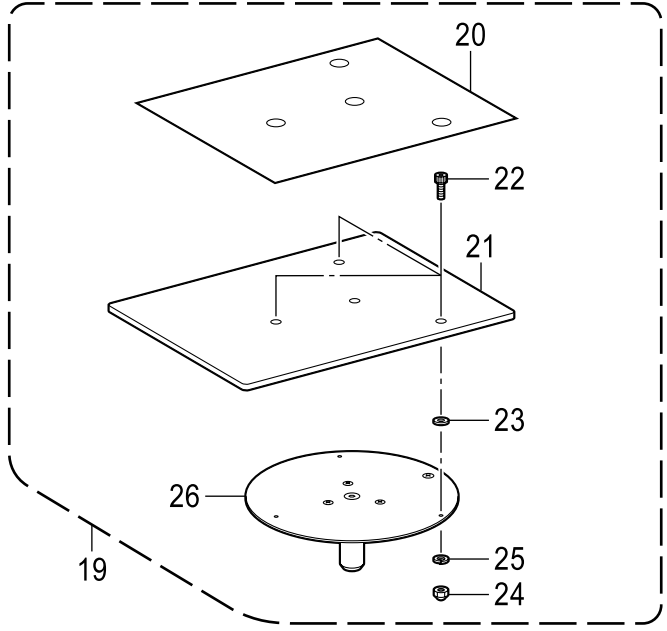
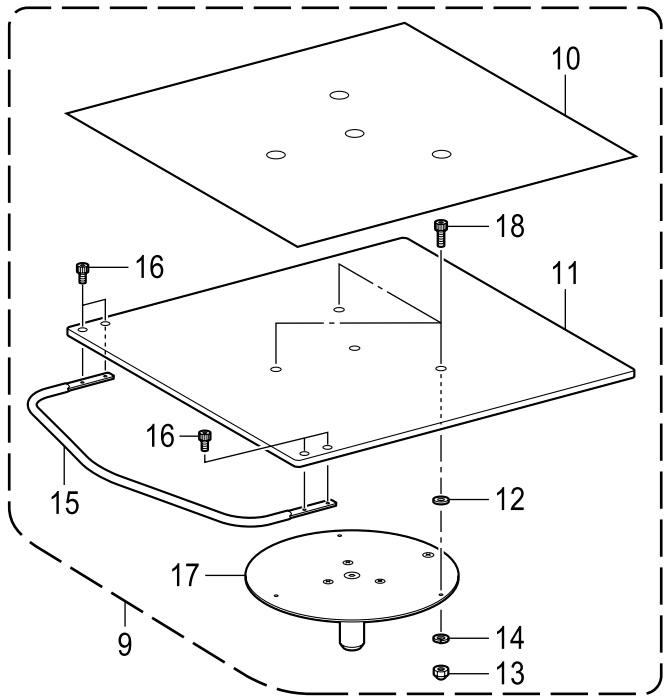
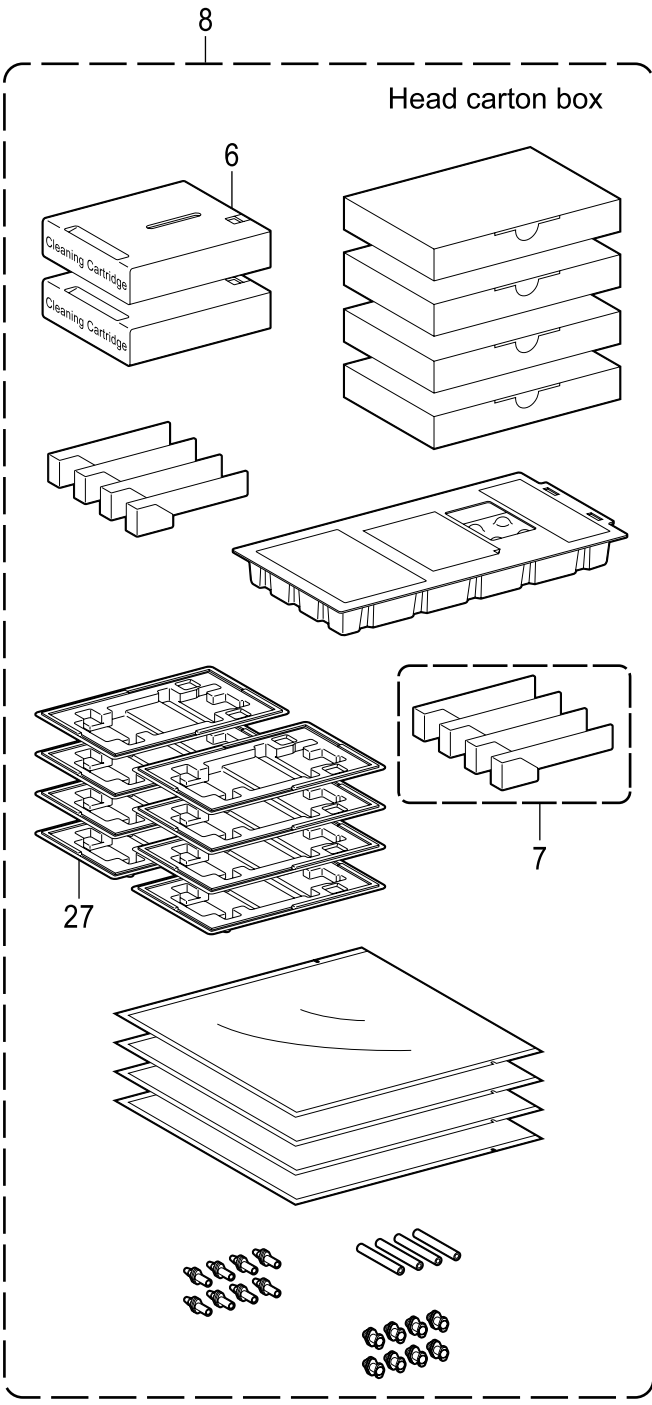
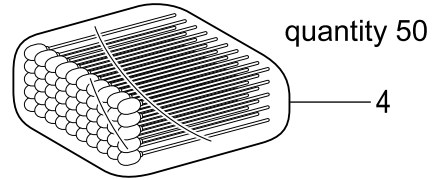
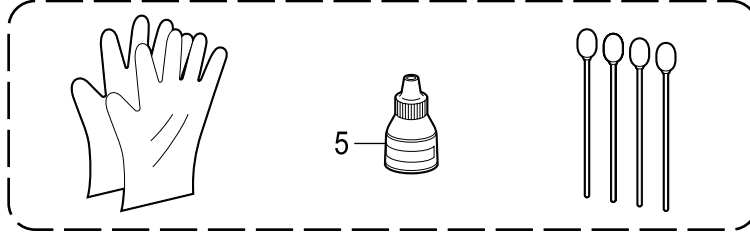
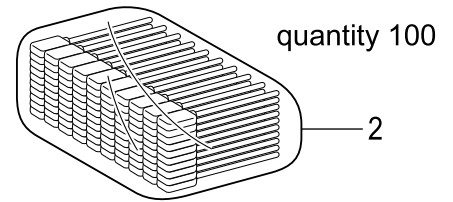
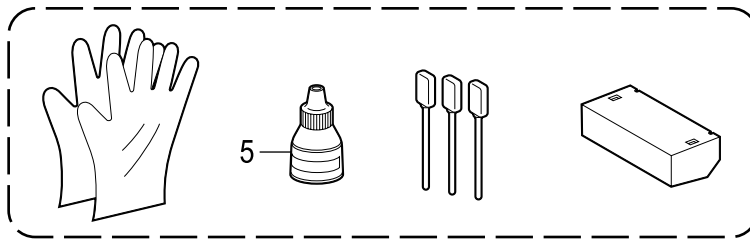

## Sp. 特別注文部品 / Option parts

REF.NO	CODE	Q'TY	品名	NAME OF PARTS	RM
1	SA5774201	1	キャップクリーニングキット	CAP CLEANING KIT	
2	SA5784001	1	クリンステイツク 100	CLEAN STICK 100	
3	SA5885201	1	ノズルクリーニングキット	NOZZLE CLEANING KIT	
4	SA5888001	1	クリーンアプリーケーター 50	CLEAN APPLICATOR 50	
5	SA6248201	1	ウォッシュエキクミ	WASH LIQUID ASSY	
6	SA5718201	1	クリーニングカートリッジクミ	CLEANING CARTRIDGE ASSY	
7	SA6292001	1	ノズルホゴフィルム 4	NOZZLE PROTECT FILM 4	
8	SA5719201	1	サービスキット	SERVICE KIT	
9	SA6399301	1	ユースプラテン	YOUTH PLATEN	
10	SA6401101	1	プラテンシートS	PLATEN SEAT S	
11	SA6402001	1	プラテンテンイタ10X12	PLATEN TOP PLATE 10X12	
12	154599000	3	ソレノイドクツシヨン	SOLENOID CUSHION	
13	S00505001	3	ロツカクフクロナツトM4	NUT, CAP M4	
14	028040246	3	バネザガネ2-4	WASHER SPRING 2-4	
15	SA6403001	1	シヨルダ-バーS	SHOULDER BAR S	
16	018400636	4	アナボルト4X6	BOLT SOCKET M4X6	
17	SA5614001	1	プラテンササエクミ	PLATEN SUPPORT ASSY	
18	018401236	3	アナボルト4X12	BOLT SOCKET M4X12	
19	SA8213301	1	ベビ-プラテン	BABY PLATEN	
20	SA8211101	1	プラテンシートSS	PLATEN SHEET SS	
21	SA8212101	1	プラテンテンイタ7X8	PLATEN TOP PLATE 7X8	
22	018401236	3	アナボルト4X12	BOLT SOCKET M4X12	
23	154599000	3	ソレノイドクツシヨン	SOLENOID CUSHION	
24	S00505001	3	ロツカクフクロナツトM4	NUT, CAP M4	
25	028040246	3	バネザガネ2-4	WASHER SPRING 2-4	
26	SA5614001	1	プラテンササエクミ	PLATEN SUPPORT ASSY	
27	SA5847001	8	IH ヘッドケース	IH HEAD CASE	

## 索引 / Index

CODE	REF.NO	Page	CODE	REF.NO	Page	CODE	REF.NO	Page	CODE	REF.NO	Page
004300806	B1 - 11	4	028050246	C1 - 51	8	0A5300806	E2 - 7	20	LG2239001	E2 - 5	20
004400803	B2 - 12	6	037300815	F - 31	22		E2 - 26	20	LG4618001	J1 - 20	26
004401003	C1 - 45	8	047201442	D - 48	12		E2 - 30	20	S00480000	J2 - 6	28
008400604	B1 - 6	4	047301042	D - 83	14		E2 - 36	20	S00505001	C2 - 5	10
	B1 - 24	4	047301242	E2 - 39	20		E2 - 38	20		C2 - 13	10
	B2 - 15	6	047603642	C1 - 9	8		J1 - 47	26		C2 - 24	10
	B2 - 17	6	048030346	E1 - 68	18	0A5301006	E1 - 79	18		Sp - 13	40
	B2 - 18	6	048040346	E1 - 30	16		J1 - 29	26		Sp - 24	40
012060636	C1 - 5	8		E1 - 38	16	0A5301606	E1 - 29	16	S00554000	E1 - 90	18
	C1 - 53	8		E1 - 44	16		H - 16	24		J1 - 13	26
	D - 6	12		E1 - 72	18		H - 19	24	S03607001	D - 64	14
	D - 9	12	048050342	D - 74	14	0A5400806	E1 - 7	16	S04159000	D - 104	14
012300536	D - 41	12	048060342	C1 - 14	8		E1 - 10	16		F - 48	22
012400436	C1 - 22	8		C1 - 31	8		E1 - 12	16		H - 24	24
012500536	C1 - 8	8		D - 43	12		E1 - 17	16		H - 28	24
	C1 - 16	8		D - 55	12		E1 - 23	16		J1 - 19	26
	C1 - 18	8	048070346	E1 - 64	18		E1 - 55	18		J1 - 23	26
	D - 12	12	048280142	D - 13	12		E1 - 97	18	S04505000	A - 8	2
	D - 46	12	060400616	B1 - 19	4		E2 - 22	20	S06696004	J1 - 50	26
018061036	B1 - 14	4		C1 - 57	8		E2 - 24	20	S09141000	A - 9	2
018300836	E1 - 87	18		L - 7	32		E2 - 31	20	S17021000	A - 6	2
	F - 5	22	062300816	C1 - 59	8		E2 - 45	20	S17022000	A - 7	2
	H - 8	24		J1 - 33	26		J1 - 1	26		J2 - 4	28
018400636	C2 - 8	10	062301016	B2 - 25	6		J1 - 22	26	S25283001	H - 11	24
	C2 - 16	10	070688850	C1 - 13	8		J1 - 25	26	S34413000	D - 93	14
	Sp - 16	40		C1 - 30	8		J1 - 54	26	S37059001	J1 - 42	26
018400836	C1 - 38	8		D - 44	12		J2 - 8	28	S37060001	J1 - 53	26
	C1 - 61	8		D - 56	12	0A5401006	B1 - 17	4	S40660000	D - 98	14
	D - 16	12	081001670	D - 23	12		B1 - 41	4	S42446001	E1 - 13	16
018401236	C2 - 4	10	083300615	L - 5	32		B2 - 2	6		H - 12	24
	C2 - 18	10	085300816	E2 - 2	20		B2 - 5	6	S43274000	J1 - 30	26
	C2 - 22	10		E2 - 11	20		B2 - 8	6	S43275000	E1 - 16	16
	D - 20	12		E2 - 13	20		B2 - 20	6		F - 45	22
	Sp - 18	40		L - 6	32		C1 - 48	8		J1 - 26	26
	Sp - 22	40	0A4303506	E2 - 15	20		D - 33	12		J2 - 3	28
018402036	C1 - 24	8	0A4400606	J1 - 15	26		D - 37	12	S45316001	D - 8	12
	C1 - 33	8	0A4403006	B2 - 22	6		D - 58	12	S47269001	C1 - 3	8
	D - 53	12		E1 - 84	18		D - 66	14		C1 - 11	8
018402536	D - 19	12	0A5300606	D - 26	12		E1 - 88	18		C1 - 26	8
018501036	C1 - 35	8		D - 31	12		F - 50	22		D - 2	12
	C1 - 50	8		D - 76	14	0A5401406	B1 - 3	4		D - 4	12
021100205	F - 22	22		D - 78	14		B1 - 25	4		F - 39	22
021300206	B1 - 9	4		D - 81	14		E1 - 25	16	S47270001	A - 3	2
	H - 9	24		D - 88	14	0A5403006	F - 33	22	S50423000	E1 - 98	18
021400206	B1 - 42	4		D - 92	14	104821001	B1 - 4	4		J1 - 31	26
025030236	B1 - 10	4		F - 10	22		B2 - 23	6		J2 - 5	28
	F - 6	22		F - 14	22	142721001	Z - 4	34	S52162000	E2 - 48	20
025050236	E1 - 52	18		F - 17	22	149547000	A - 10	2		J1 - 49	26
	F - 9	22		F - 20	22	154599000	C2 - 2	10	S52163000	E2 - 49	20
	F - 13	22		F - 25	22		C2 - 12	10		J1 - 48	26
026030135	L - 4	32		F - 27	22		C2 - 23	10	S55479001	A - 5	2
026040236	D - 21	12		H - 4	24		Sp - 12	40		B2 - 33	6
026060250	E1 - 26	16		H - 6	24		Sp - 23	40		C1 - 20	8
	E1 - 34	16		J1 - 8	26	3A6001003	D - 39	12		C1 - 28	8
	E1 - 43	16		J1 - 11	26	624771000	E1 - 6	16		C1 - 40	8
	E1 - 71	18	0A5300806	E1 - 21	16	625010000	E1 - 5	16		C1 - 42	8
028030246	B1 - 44	4		E1 - 46	16	GC-50C	Co - 3	38		D - 105	14
028040246	C2 - 6	10		E1 - 66	18	GC-50K	Co - 1	38		F - 3	22
	C2 - 14	10		E1 - 76	18	GC-50M	Co - 2	38		F - 40	22
	C2 - 25	10		E1 - 82	18	GC-51Y	Co - 4	38		H - 20	24
	Sp - 14	40		E1 - 92	18	J04115001	J1 - 4	26		H - 25	24
	Sp - 25	40		E1 - 96	18		Wa1	35		H - 29	24
028050246	C1 - 36	8		E1 - 103	18	LG2239001	D - 90	14		H - 33	24

CODE	REF.NO	Page	CODE	REF.NO	Page	CODE	REF.NO	Page	CODE	REF.NO	Page
S55479001	J1 - 34	26	SA5469001	F - 44	22	SA5620201	Co - 6	38	SA5885201	Z - 1	34
	J2 - 1	28	SA5470001	J1 - 21	26	SA5621101	C2 - 3	10		Sp - 3	40
	L - 9	32	SA5471001	D - 57	12	SA5622001	C2 - 7	10	SA5888001	Sp - 4	40
S55481001	D - 50	12	SA5472001	D - 59	12	SA5623001	F - 1	22	SA5896201	Z - 2	34
	D - 52	12	SA5473001	D - 60	12	SA5624001	F - 2	22	SA5915001	E1 - 80	18
	D - 61	12	SA5474001	D - 62	12	SA5625001	F - 4	22	SA5916001	E1 - 4	16
	D - 63	14	SA5475001	D - 65	14	SA5626001	F - 7	22		E2 - 19	20
	D - 68	14	SA5476001	D - 67	14	SA5627101	L - 3	32	SA5917001	E1 - 8	16
	D - 70	14	SA5477001	D - 69	14	SA5628101	F - 11	22	SA5921001	E1 - 14	16
SA3573001	J1 - 28	26	SA5481001	D - 75	14	SA5629201	Co - 5	38		E2 - 17	20
SA4463001	E1 - 105	18	SA5482001	D - 77	14	SA5630001	F - 15	22	SA5922001	E1 - 15	16
SA5343201	J1 - 5	26	SA5483001	D - 79	14	SA5631001	F - 16	22	SA5925001	E1 - 18	16
SA5348001	B1 - 40	4	SA5484001	D - 80	14	SA5632001	F - 18	22	SA5926001	E1 - 19	16
SA5357101	L - 1	32		F - 8	22	SA5633001	F - 19	22	SA5927001	E1 - 20	16
SA5360001	L - 2	32		F - 12	22		H - 3	24	SA5928001	E1 - 22	16
SA5365101	F - 41	22	SA5485001	D - 82	14	SA5634001	F - 21	22	SA5929001	E1 - 24	16
SA5367101	F - 42	22	SA5489001	E1 - 77	18	SA5635001	F - 23	22	SA5931001	E1 - 27	16
SA5369101	E1 - 102	18	SA5490001	E2 - 33	20	SA5636001	F - 24	22	SA5932001	E1 - 28	16
SA5376101	D - 86	14	SA5491001	E1 - 86	18	SA5637001	F - 26	22	SA5933001	D - 71	14
SA5379001	C1 - 58	8	SA5492101	E1 - 78	18	SA5638001	F - 28	22		E1 - 31	16
SA5380001	K - 1	30	SA5493001	F - 38	22	SA5639001	F - 29	22		E1 - 36	16
SA5381001	J1 - 39	26	SA5497001	E2 - 34	20	SA5640001	F - 30	22		E1 - 73	18
SA5382001	J1 - 38	26	SA5498001	B2 - 31	6	SA5641001	F - 32	22	SA5934001	E1 - 32	16
SA5383101	J1 - 36	26	SA5511101	L - 12	32	SA5642001	F - 34	22	SA5935001	E1 - 35	16
SA5384001	J1 - 35	26	SA5515001	A - 4	2	SA5643001	F - 35	22	SA5937001	E1 - 39	16
SA5385101	J1 - 16	26	SA5516001	D - 27	12	SA5644001	F - 36	22	SA5938001	E1 - 40	16
SA5386001	J1 - 17	26	SA5517001	D - 99	14	SA5645001	H - 1	24	SA5939001	E1 - 41	16
SA5387001	J1 - 18	26	SA5518001	D - 96	14	SA5646001	H - 2	24	SA5940001	E1 - 45	16
SA5388001	L - 11	32	SA5519001	D - 73	14	SA5648001	H - 5	24	SA5941001	E1 - 47	16
SA5389001	K - 2	30	SA5520001	D - 100	14	SA5649001	H - 7	24	SA5943001	E1 - 49	16
SA5390001	F - 43	22	SA5586001	H - 31	24	SA5650001	H - 10	24	SA5945001	E1 - 51	18
SA5391001	K - 3	30	SA5587001	B2 - 19	6	SA5651001	H - 13	24	SA5948101	E1 - 53	18
SA5392001	K - 4	30	SA5589001	C1 - 1	8	SA5652001	H - 14	24	SA5949101	E1 - 54	18
SA5393001	K - 8	30	SA5591001	C1 - 4	8	SA5653001	H - 15	24	SA5950001	E1 - 56	18
SA5394001	K - 5	30	SA5592001	C1 - 6	8		H - 18	24	SA5951001	E1 - 57	18
SA5395001	D - 87	14	SA5593001	C1 - 7	8	SA5654001	H - 17	24	SA5952001	E1 - 58	18
SA5396001	E1 - 104	18		D - 11	12	SA5656001	H - 21	24	SA5953001	D - 84	14
SA5397101	D - 89	14	SA5594001	C1 - 10	8	SA5657001	H - 22	24		E1 - 59	18
SA5398001	H - 30	24	SA5595001	C1 - 12	8	SA5658001	H - 23	24	SA5957101	E1 - 61	18
SA5399001	C1 - 60	8	SA5596001	C1 - 15	8	SA5659101	B1 - 29	4	SA5958001	E1 - 62	18
SA5400001	L - 10	32	SA5597001	C1 - 17	8	SA5660001	H - 26	24	SA5959001	E1 - 63	18
SA5438001	D - 1	12	SA5598001	C1 - 19	8	SA5661001	H - 27	24		E2 - 43	20
SA5439001	D - 3	12	SA5599001	C1 - 21	8	SA5664001	D - 91	14	SA5960001	E1 - 65	18
SA5440001	D - 5	12	SA5600001	C1 - 23	8	SA5718201	Sp - 6	40	SA5961001	E1 - 67	18
SA5441001	D - 7	12	SA5601001	C1 - 25	8	SA5719201	Sp - 8	40	SA5962001	E1 - 69	18
SA5443001	C1 - 54	8	SA5602001	C1 - 27	8	SA5736101	E1 - 11	16	SA5963001	E1 - 70	18
SA5445001	D - 14	12		D - 51	12	SA5761001	J1 - 3	26	SA5965001	E1 - 75	18
SA5446001	C1 - 55	8	SA5603001	C1 - 29	8	SA5762001	C1 - 2	8		E2 - 29	20
SA5451001	D - 22	12		D - 54	12	SA5772201	Wa1	35	SA5966001	E1 - 100	18
SA5452001	D - 24	12	SA5604001	C1 - 32	8	SA5774201	Sp - 1	40	SA5969001	E1 - 101	18
SA5453001	D - 25	12	SA5607001	C1 - 39	8	SA5783201	Wa2	36	SA5971001	E1 - 81	18
SA5454001	D - 28	12	SA5608001	C1 - 41	8	SA5784001	Sp - 2	40	SA5972001	E1 - 83	18
SA5455001	D - 29	12	SA5609001	C1 - 43	8	SA5806201	Wa1	35	SA5973001	E1 - 85	18
SA5456001	D - 30	12	SA5610001	C1 - 46	8	SA5814001	B1 - 31	4	SA5974001	E2 - 1	20
SA5459001	F - 49	22	SA5611001	C1 - 49	8	SA5815001	B1 - 32	4	SA5975001	E2 - 3	20
SA5460001	D - 36	12	SA5612001	C1 - 52	8	SA5816001	B2 - 26	6	SA5976001	E2 - 4	20
SA5461001	D - 38	12	SA5613001	C1 - 56	8	SA5817001	B2 - 27	6	SA5977001	E2 - 6	20
SA5463001	L - 8	32	SA5614001	C2 - 1	10	SA5818101	C1 - 47	8	SA5978001	E2 - 8	20
SA5464001	D - 40	12		C2 - 17	10	SA5825201	Wa1	35	SA5979001	E2 - 9	20
SA5465001	D - 42	12		C2 - 26	10	SA5846201	F - 46	22	SA5980001	E2 - 10	20
SA5466001	D - 45	12		Sp - 17	40	SA5847001	Sp - 27	40	SA5981001	E2 - 12	20
SA5467001	D - 47	12		Sp - 26	40	SA5884001	F - 47	22	SA5982001	E2 - 14	20
SA5468001	D - 49	12	SA5619101	B1 - 27	4		Wa2	36	SA5983001	E2 - 16	20

## 索引 / Index

CODE	REF.NO	Page	CODE	REF.NO	Page	CODE	REF.NO	Page	CODE	REF.NO	Page
SA5984001	E1 - 89	18	SA6317201	B2 - 29	6	SA9151001	B1 - 23	4			
SA5986001	E2 - 32	20		Wa1	35	SA9219001	J2 - 7	28			
SA5988001	E2 - 40	20	SA6318301	Wa2	36	SA9221001	J2 - 2	28			
SA5989001	E2 - 41	20	SA6321001	B1 - 39	4	SA9222001	Z - 7	34			
SA5990001	E2 - 42	20	SA6322301	Wa2	36	SA9223001	Z - 5	34			
SA5992001	E1 - 93	18	SA6323201	B2 - 30	6	SA9957002	B1 - 46	4			
SA5993001	E1 - 94	18	SA6329101	J1 - 9	26		B2 - 34	6			
SA5995001	E2 - 23	20	SA6330101	J1 - 12	26		Wa2	36			
SA5996101	E2 - 25	20	SA6333001	E2 - 21	20	SB0001001	Z - 6	34			
SA6001001	E2 - 28	20	SA6335001	E2 - 18	20	SB0442001	J1 - 55	26			
SA6003001	E2 - 27	20		E2 - 37	20	X56655001	E1 - 42	16			
SA6004001	E2 - 44	20	SA6341001	E2 - 47	20	XA0199001	E1 - 33	16			
SA6007001	A - 1	2	SA6365001	J1 - 27	26		E1 - 37	16			
SA6008001	H - 32	24	SA6372001	B1 - 7	4		E1 - 74	18			
SA6009001	A - 2	2	SA6379201	B1 - 37	4	XA0199051	D - 72	14			
SA6031001	J1 - 7	26	SA6380101	B1 - 28	4						
SA6040001	J1 - 37	26	SA6381101	B1 - 30	4						
SA6053001	D - 97	14	SA6399301	C2 - 9	10						
SA6054001	J1 - 32	26		Sp - 9	40						
SA6055001	B2 - 1	6	SA6401101	Sp - 10	40						
SA6056001	B2 - 3	6	SA6401201	C2 - 10	10						
SA6058001	B2 - 6	6		Co - 7	38						
SA6059001	B2 - 7	6	SA6402001	Sp - 11	40						
SA6060001	B2 - 9	6	SA6402101	C2 - 11	10						
SA6061001	B2 - 10	6	SA6403001	C2 - 15	10						
SA6062001	B2 - 11	6		Sp - 15	40						
SA6063001	B2 - 13	6	SA6452001	Z - 3	34						
SA6064001	B2 - 14	6	SA7692001	E1 - 48	16						
SA6065001	B2 - 16	6	SA7694001	E1 - 2	16						
SA6068101	B1 - 5	4	SA7695001	D - 17	12						
SA6069001	B1 - 26	4	SA7902001	D - 10	12						
SA6070001	B1 - 8	4	SA7913001	J1 - 14	26						
SA6071001	B1 - 12	4	SA7914001	J1 - 10	26						
SA6072001	B1 - 13	4	SA7918001	J1 - 52	26						
SA6073001	C1 - 44	8	SA7922001	B2 - 32	6						
SA6074001	B1 - 15	4	SA7946001	E1 - 9	16						
SA6075001	B1 - 16	4	SA7947001	B2 - 4	6						
SA6076001	B1 - 18	4	SA7979001	C1 - 34	8						
SA6078001	B2 - 24	6	SA7980001	C1 - 37	8						
SA6079001	B1 - 20	4		D - 15	12						
SA6080001	B1 - 21	4	SA8032201	Wa1	35						
SA6081001	B1 - 22	4	SA8042001	D - 32	12						
SA6089001	B1 - 43	4	SA8043001	D - 85	14						
SA6090001	J1 - 51	26	SA8211101	C2 - 20	10						
SA6144001	J1 - 41	26		Co - 8	38						
SA6145001	J1 - 40	26		Sp - 20	40						
SA6154001	J1 - 2	26	SA8212101	C2 - 21	10						
SA6155001	E2 - 35	20		Sp - 21	40						
	J1 - 24	26	SA8213301	C2 - 19	10						
SA6198001	E1 - 91	18		Sp - 19	40						
SA6199001	E1 - 95	18	SA8838001	Z - 8	34						
SA6248201	Sp - 5	40	SA8891101	B1 - 45	4						
SA6252001	E1 - 1	16	SA8892101	B1 - 33	4						
SA6253001	E2 - 46	20	SA8913101	D - 103	14						
SA6268001	J1 - 43	26		K - 6	30						
SA6269001	J1 - 44	26	SA8981001	K - 7	30						
SA6270001	J1 - 45	26	SA9001001	E1 - 60	18						
SA6271001	J1 - 46	26	SA9002001	B1 - 1	4						
SA6289101	E1 - 50	16	SA9086001	D - 102	14						
SA6292001	Sp - 7	40	SA9087001	D - 101	14						
SA6315201	B1 - 36	4	SA9088001	D - 106	14						
SA6316301	B1 - 34	4	SA9149001	B1 - 2	4						
	Wa1	35	SA9150001	B2 - 21	6						

# MEMO

brother®

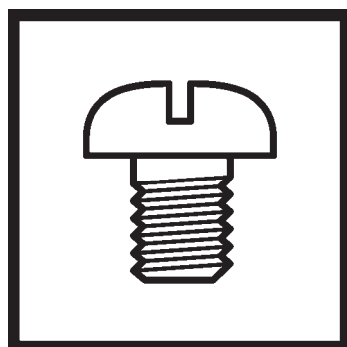

パーツブック  
PARTS BOOK

**ブラザー工業株式会社** <http://www.brother.co.jp/>

〒448-0803 刈谷市野田町北地蔵山1番地5 TEL:0120-33-2392

**BROTHER INDUSTRIES, LTD.** <http://www.brother.com/>

1-5, Kitajizoyama, Noda-cho, Kariya 448-0803, Japan. Phone : 81-566-95-0088

©2005 - 2009 Brother Industries, Ltd. All Rights Reserved.

GT-5410  
SA5698-801  
2009.6.B (1)